

COMMERCIAL MAINTENANCE MANUAL

N.S.N.: 4110-01-117-3902

REFRIGERATOR, MECHANICAL
BLOOD BANK

110/220 VOLT
50/60 HZ. A. C.

THE JEWETT REFRIGERATOR CO.
2 LETCHWORTH STREET
BUFFALO, NEW YORK 14213-1098

CONTRACT NO. DLA120 - 87 - C - 8528

MODEL NO. BBR37SS-IB-03

1987

TABLE OF CONTENTS
MAINTENANCE MANUAL

<u>PAGE</u>	<u>DESCRIPTION</u>
1	Cabinet Drawing (Fig. #1)
2	General Information/Equipment Provided
3-4	Installation Instructions
5	Operating Instructions
6	Theory of Operation/Basic Refrigeration Cycle (Fig. #2)
7	General Maintenance Instructions/Door Gasket Replacement Instructions
8	Setting Temperature Control
9	Temperature Control Drawing (Fig. #3)
10	Hinge and Latch Adjustment Instructions Hinge Details (Fig. #4)
11	Latch Adjustment Instructions Latch Details (Fig. #5)
12	Drawer Installation/Removal (Fig. #6)
13-14	Condensing Unit Data Sheet - Condensing Unit (Fig. #7) - C.U.Wiring Schematic (Fig. #8)
15-16-17	Unit Cooler Data Sheets - Basic Cooler (Fig. #9) - Component Part Locations (Fig. #10)
18	Mechanical Component Part Locations (Fig. #11)
19	Schematic Wiring Diagram (Fig. #12)
20	Storage Instructions
21-22	Replacement Parts List (Refrigerator Only)
23-24-25	Trouble Shooting Guide
26	8GR1WBR Recording Thermometer (Fig. #13)
27-28-29	General Information -Recording Thermometer

TABLE OF
CONTENTS
Maintenance Manual

<u>PAGE</u>	<u>DESCRIPTION</u>
30	Parts Locations/Recording Thermometer (Fig. #14) Recorder Case Dimensions (Fig. #15)
31	Parts List/Recording Thermometer
32	T100 Component Layout (Fig. #16)
33-34-35	T100 General Information
36	T100 Connection Diagram (Fig. #17)
37-38-39	T100 Trouble Shooting Chart
40	T100 Parts List
41	T100 Calibration Procedure (Fig. #18)
42	T100 Wiring Schematic (Fig. #19)
43-44	T100 Replacement Parts List (Main PC Board Only)
45	T100 Component Layout Diagram (Main PC Board Only) (Fig. #20)

GENERAL INFORMATION

Each Jewett Refrigerator is a complete packaged unit ready to operate when connected to electric power lines. It is not necessary to have a refrigeration serviceman place the unit in service. Each refrigerator has been given a 48-hour test prior to shipment. Read all the instructions first before proceeding with the installation.

This blood bank refrigerator has been designed and engineered in keeping with the recommended standard temperature requirements established by the American Association of Blood Banks, the American National Red Cross and the Food and Drug Administration.

This blood bank refrigerator with a "brain" features a temperature surveillance module which insures safe, continuous monitoring of upper & lower solution temperatures. Stainless steel, removable, adjustable drawers with full extension ball bearing slides provide easy access.

Digital display of upper & lower solution temperature in Celsius.

Monitor indicator lights display low, safe, and high temperature of stored contents.

Dual circulation cooling fan.

Temperature monitor audible signal with timer re-set switch.

Door ajar indicator light and audible signal.

Recording thermometer - 7 day chart.

This blood bank refrigerator is equipped with the following items:

EQUIPMENT PROVIDED

1. T100-1 Temperature Surveillance Module.
2. 8GR1WBR Record Thermometer.
3. Dual Voltage/Cycle Transformer.

See sections on MODULE and RECORDING THERMOMETER for information on these items.

INSTALLATION INSTRUCTIONS

1. Measure all doorways and passageways for clearance before moving cabinet. This model will pass through standard 30" x 84" door openings.

Note: Additional clearance front to back may be gained by removing the condensate evaporator assembly, channel guards and drain tube from back of the cabinet. To remove the drain tube - detach the rubber tube located below the unit cooler inside the refrigerator, then with a slight twisting motion, pull drain tube from back of cabinet. Do not disconnect wiring on condensate evaporator assembly. Flexible armored cable will permit sufficient movement to swing assembly to top or side of refrigerator.

2. Move the refrigerator into the desired location, making sure the bottom of the refrigerator is evenly supported. If the cabinet sets on an uneven surface a slight rocking or vibration might result when the condensing unit is set in operation. This model has adjustable legs to compensate for uneven floors. Adjust as required to level cabinet in all directions.
3. Inspect the interior and exterior of the refrigerator including the mechanical equipment for special instructions and tags fastened at various points.
4. Make certain that cabinet is located so that the rear of the mechanical compartment is unobstructed to allow for ventilation for the condensing unit.

NOTE: Minimum of 8" clearance required between ceiling and top of refrigerator to allow for adequate ventilation of mechanical equipment. Minimum of 3" clearance at rear.

5. All models have been provided with electric condensate evaporators, located on the back of the cabinet. Periodic cleaning of the condensate pan will assure proper operation. Caution: unit is Hot. Avoid contact with heating elements with refrigerator running.
6. The hermetic sealed condensing unit (1/5 HP) is shipped with all service valves open and ready for operation. Do not adjust valves. The unit is designed to operate on 110 volt, 50/60 cycle, or 220 volt, 50/60 cycle, alternating current. Use of any other electrical characteristics may cause permanent damage to the electrical components.

INSTALLATION INSTRUCTIONS (cont'd)

7. Provide (1) 3-wire grounding type convenience outlet within 6 feet of the junction box located in the condensing unit compartment. Connect refrigerator plug in cord into wall outlet. Make sure main power switch is off (switch is in mechanical space). Be sure the electric line is the proper size to carry the load. Low voltage due to line loss or line overload will cause the compressor overload to cut out. Excessive cycling could cause overheating and damage the motor windings.

Adjust internal jumpers in transformer as follows:

110V/50 HZ - A TO 5
 B TO 6

110V/60 HZ - A TO 6
 B TO 6

220V/50 HZ - A TO 3
 B TO 6

220V/60 HZ - A TO 3
 B TO 5

CAUTION: DO NOT OPEN COVER OF TRANSFORMER WHEN CONNECTED TO POWER SOURCE
HAZARDOUS VOLTAGES INSIDE. MAKE SURE POWER SWITCH IS OFF.

8. All controls have been checked and adjusted at the factory. After the cabinet has been set in operation, allow the refrigerator several hours to cool the cabinets interior and insulation as well as the product load. Apparent erratic operation on initial start-up does not necessarily indicate that the mechanism is faulty. After the mechanism has been allowed to bring the refrigerator down to normal operating temperature, the unit will cycle regularly.
9. Every effort has been made to use standard parts throughout the refrigerator. Therefore, mos parts of the refrigerating system can be obtained at any refrigeration supply dealer and can be repaired, serviced or replaced by any competent service company.

OPERATING INSTRUCTIONS

CAUTION: MAKE SURE TRANSFORMER IS SET UP FOR PROPER ELECTRICAL VOLTAGE & FREQUENCY BEFORE PLUGGING IN UNIT

- 1) REFRIGERATOR IS DESIGNED TO OPERATE AT 110/220V - 50/60HZ - 1 PHASE POWER. OPERATION AT ANY OTHER POWER MAY CAUSE PERMANENT DAMAGE TO MECHANISM. SEE LABEL AT TOP MOUNTED TRANSFORMER FOR INSTRUCTIONS ON ADJUSTMENTS TO SUIT AVAILABLE VOLTAGE & FREQUENCY.
- 2) THE COOLING COIL FAN RUNS CONTINUOUSLY. THE COIL DEFROSTS AUTOMATICALLY ON COMPRESSOR OFF CYCLE.
- 3) DUAL TEMPERATURE CONTROLS ARE FACTORY SET TO OPERATE ON 36°F TO 40°F AIR TEMPERATURE. IF ONE CONTROL IS CHANGED, THE SECOND CONTROL MUST BE CHANGED ACCORDINGLY.
- 4) CLEAN THE FAN COIL OF THE CONDENSING UNIT PERIODICALLY. ALSO CLEAN THE INTERIOR CABINET AND DRAWERS OFTEN, USING WARM WATER AND A GOOD FUNGICIDAL DETERGENT.

This unit is equipped with dual controls and operates at +2° to 4°C (36°F to 40°F). The second temperature control has been installed for extra protection against temperature failures. If one temperature control should fail to close, the second temperature control automatically takes over. If the setting of one temperature control is changed, the second control must be changed accordingly. A reliable serviceman should inspect the controls yearly to assure that both are in good condition. These controls have been factory preset. See Maintenance Section for resetting information. This unit is designed for continuous operation.

To turn off refrigerator, unplug transformer from power source, or turn off power switch.

For operation of MODULE/RECORDING THERMOMETER, see applicable sections.

THEORY OF OPERATION

THE BASIC REFRIGERATION CYCLE

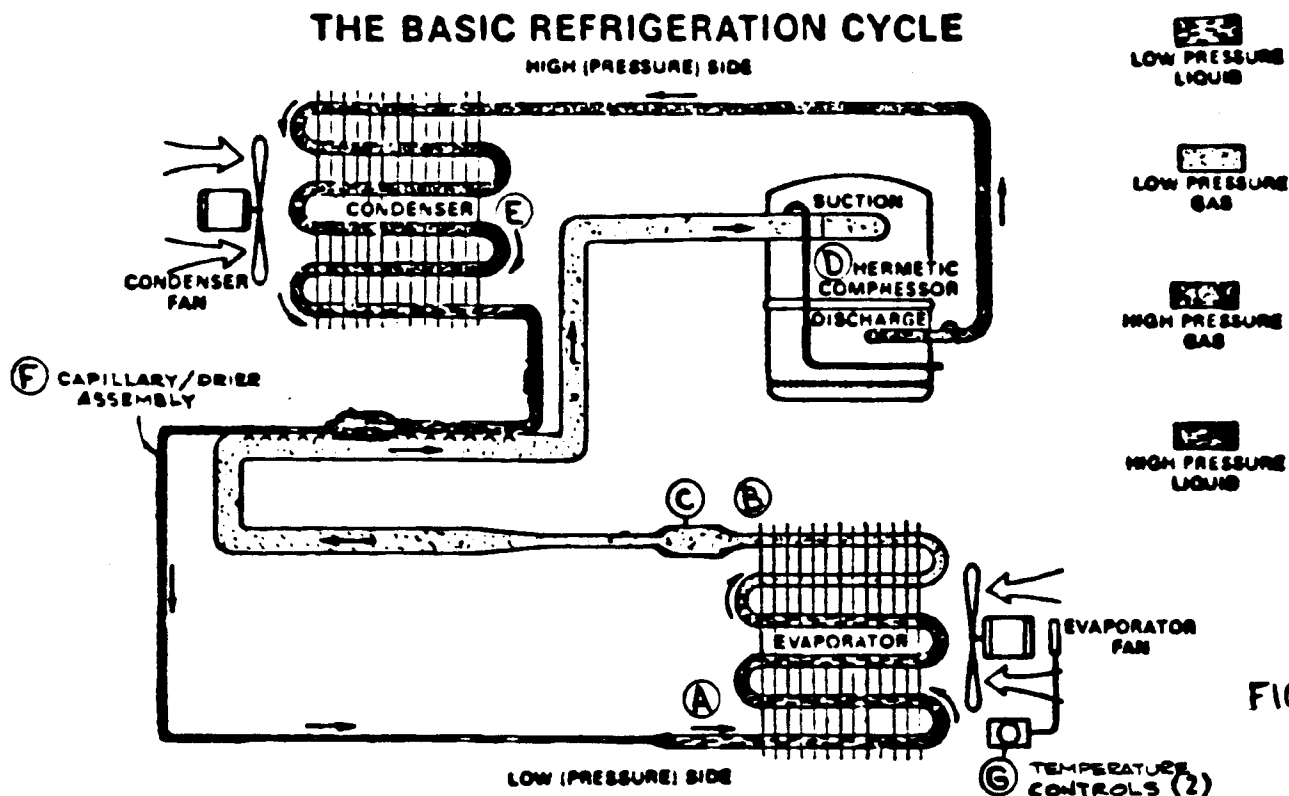

FIG:2

Mechanical refrigeration is accomplished by continuously circulating, evaporating, and condensing a fixed supply of refrigerant in a closed system. Evaporation occurs at a low temperature and low pressure while condensation occurs at a high temperature and pressure. Thus, it is possible to transfer heat from an area of low temperature (i.e., refrigerator cabinet) to an area of high temperature (i.e., Lab Room).

Beginning the cycle at the evaporator inlet (A) the low pressure liquid expands, absorbs heat, and evaporates, changing to a low pressure gas at the evaporator outlet (B).

The compressor (D) pumps this gas from the evaporator through the accumulator (C), increases its pressure, and discharges the high pressure gas to the condenser (E). The accumulator is designed to protect the compressor by preventing slugs of liquid refrigerant from passing directly into the compressor. An accumulator should be included on all systems subjected to varying load conditions or frequent compressor cycling. In condenser (E) heat is removed from the gas which then condenses and becomes a high pressure liquid.

As the high pressure liquid refrigerant enters the evaporator (A) it is subjected to a much lower pressure due to the suction of the compressor and the pressure drop across the capillary/drier assembly (F). Thus, the refrigerant tends to expand and evaporate. In order to evaporate, the liquid must absorb heat from the air passing over the evaporator.

Eventually, the desired air temperature is reached and the temperature control (G) will break the electrical circuit to the compressor motor and stop the compressor.

As the temperature of the air through the evaporator rises, the temperature control remakes the electrical circuit. The compressor starts, and the cycle continues.

GENERAL MAINTENANCE INSTRUCTIONS

1. To protect the cabinet finish as well as the product, the refrigerator should be cleaned often using luke warm water and a good fungicidal detergent to eliminate air borne low temperature growing organisms.
2. The drawers should also be wiped occasionally to prevent the accumulation of any foreign matter. The drawer slides do not require any lubrication.
3. The fan in the unit cooler operates continuously and needs no lubrication.
4. The condensing unit in the top of the cabinet is completely sealed and needs no oiling or other lubrication. However, the finned condensing unit through which air passes can become clogged with lint and other foreign substances in the air. The openings between the fins should be cleaned of lint every few months. A small test tube brush works well for this purpose.
5. An annual inspection of the mechanical refrigerating equipment by a competent service man is recommended, as a mechanic can frequently make adjustments which prevent a breakdown in the future.
6. The refrigeration system is charged with Freon R-12. If the system is opened for any reason, extreme care should be taken to prevent the entry of moisture-bearing air and a good drier should be installed in the lines when the system is again closed.

See sections on MODULE/RECORDING THERMOMETER for information on these items.

DOOR GASKET REPLACEMENT INSTRUCTIONS

1. It is recommended that door be removed from cabinet and laid in a flat position, to ease removal and replacement of gasket.
2. Remove screws holding inner door metal and gasket. Note position of door metal before lifting off, to assure proper alignment of screwholes.
3. Replace old gasket with new gasket, slide inner door metal into position and align screwholes. Adjust gasket so that it fits within the edge of the exterior door pan.
4. Inner door metal can now be secured in place and door remounted on cabinet.
5. Check for proper gasket seal and ease of operation. Should any adjustments be required, follow procedures listed on Fig. 4 & 5 Pages 10 & 11

INSTRUCTIONS FOR SETTING CUTLER HAMMER CONTROL
OF JEWETT REFRIGERATORS

OPERATION: Cutler Hammer Control CTLO01 is a single pole, single break switch with snap acting toggle that CLOSES the circuit on INCREASE & OPENS the circuit on DECREASE in temperature.

"OFF-ON" SWITCH: Turn dial knob "Counter-clockwise" to reach "OFF" position.

DIAL KNOB: Turning the cam WITH THE DIAL KNOB changes the "cut-out" setting only. Changing the dial knob position DOES NOT CHANGE THE CUT-IN SETTING.

TURN DIAL KNOB: "Counter-clockwise" for WARMER "Clockwise" for COLDER OPERATION range setting.

NOTE: THE FOLLOWING ADJUSTMENTS TO BE MADE BY AUTHORIZED PERSONNEL ONLY.

TURN CUT-IN OR CUT-OUT SCREW: "Counter-clockwise" for WARMER, "Clockwise" for COLDER temperature setting.

TO RESET CONTROL: Turn knob of one control to the off position. Turn knob on other control to the #6 position and set temperature as follows: The cut-in and cut-out adjustments are independent and separate. Therefore, the adjustment of one does not affect the operating point of the other. The cut-in point should be set first, i.e. set control to cut-in +4°C. (+40°F) air temperature. When this has been accomplished, the cut-out point should be set to stop the condensing unit when air temperature reaches +2°C. (+36°F). Adjustments should be made a 1/4 of a turn at a time until desired operation is achieved. Sufficient time should be allowed between adjustments so that the system may balance out properly. When the control has been adjusted to hold the proper temperature range, reverse procedure and recalibrate control. These adjustments to be made only if temperature range cannot be adjusted by the Dial Knob.

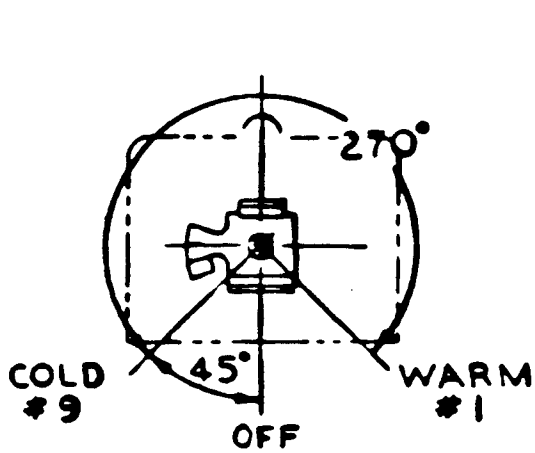

DIAL LAYOUT
CONTROL SHOWN IN OFF

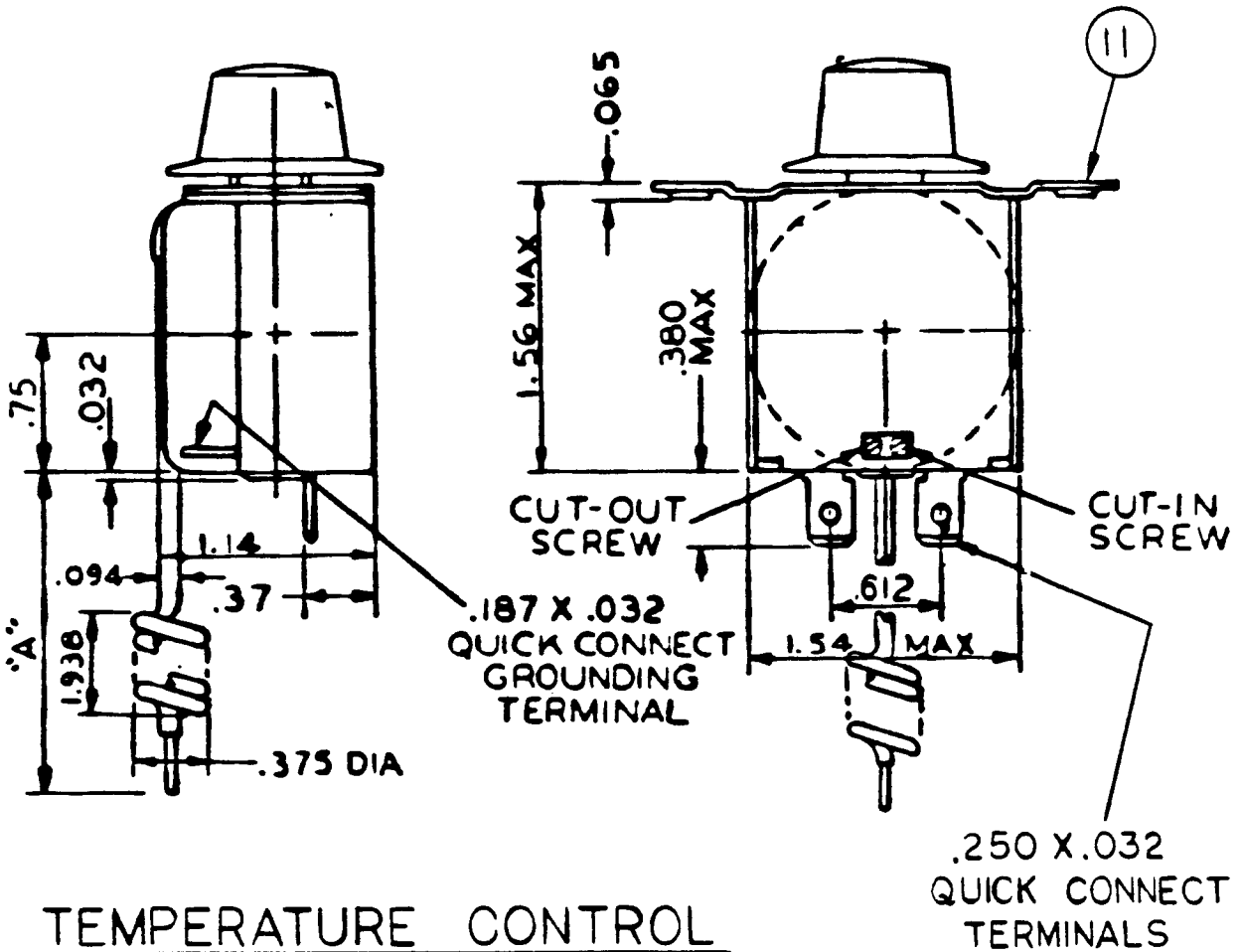
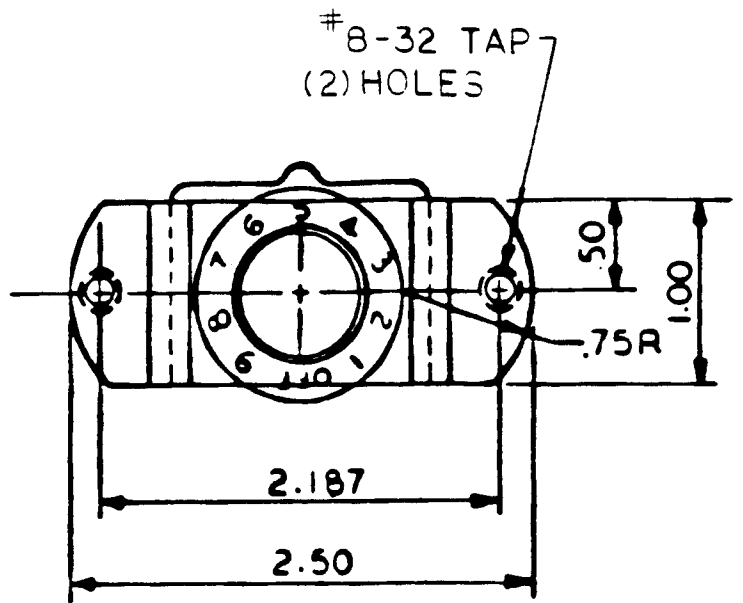

TEMPERATURE CONTROL
(CUTLER-HAMMER-CTLOO1)

FIG. #3

SEE PARTS LIST FOR
ITEM IDENTIFICATION

HINGE ADJUSTMENTManufacturerManufacturer Part NumberJewett Part Number

Klein

2842-1009 - 1 1/8" Offset

HGS005

HINGE ADJUSTMENT

- A. Remove exterior hinge cover plate by opening refrigerator door. Place screwdriver under interior portion of cover, gently pry cover outward. Pull straight out. Close door.
- B. Loosen the three (3) screws "B" which hold adjusting plate "C" in position.
- C. To tighten gasket seal, place hand against exterior of door near hinges, gently press in on door so gasket sits firmly against cabinet face. Tighten screws "B".
- D. When adjustment is complete, if hinges are adjusted so gasket seal is too tight, door will tend to spring open. Door must be readjusted. To test gasket seal - insert a dollar bill (or piece of paper of similar size) between the gasket and cabinet opening; close door - a slight resistance to removal of the dollar bill (test strip) should be felt - check perimeter of door. If latch door is loose, see latch adjusting information Page 11
- E. Replace cover plate "A".

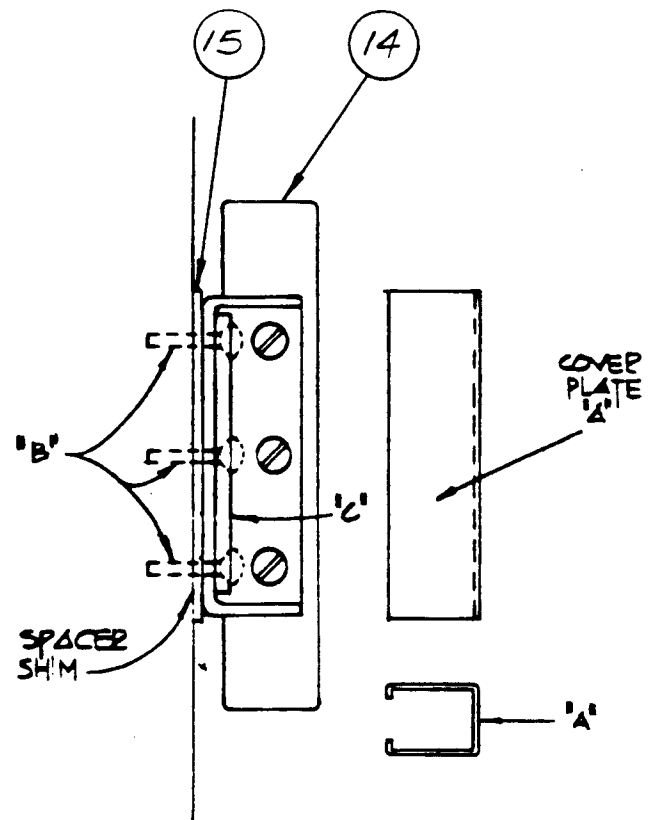

FIG. #4

NOTE: To accomplish different offsets, shims are utilized. If replacing hinges, make sure to reuse any shims furnished on cabinet.

SEE PARTS LIST FOR ITEM IDENTIFICATION

LATCH ADJUSTMENTManufacturerManufacturer Part NumberJewett Part Number

Klein

2830-2110

FSK010

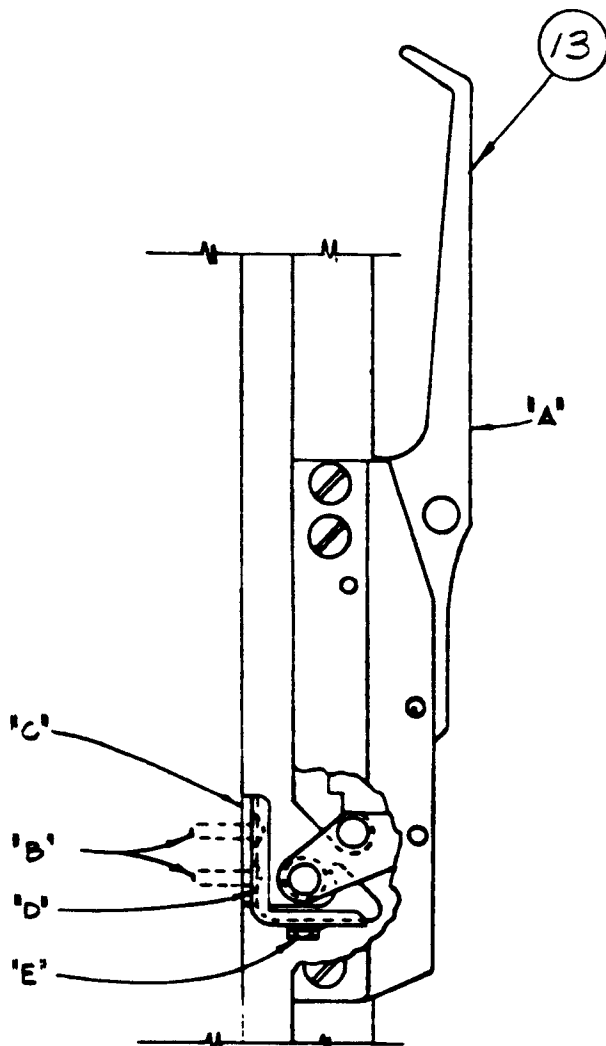
LATCH AND STRIKE ADJUSTMENT

- A. Latch as fastened to door.
- B. For up or down adjustment (proper latch engagement), loosen mounting screws "B".
- C. Strike plate "C" remains in position.
- D. Move strike "D" up or down as required and tighten screws "B" when adjustment is satisfactory. No play will be present in latch handle with door closed.
- E. For in and out adjustment (proper gasket seal), loosen screw "E". Adjust in or out as required and retighten screw when adjustment is satisfactory.

NOTE: This stainless steel hex head cap screw is 10-32 x 5/16 long, or use Jewett part number BLT03C02A006. Use box wrench, open end wrench, or ratchet to tighten. Do not use a nut driver or pliers.

FIG. #5

NOTE: If replacing latch and strike assembly, make sure to reuse any shims furnished on cabinet.

SEE PARTS LIST FOR ITEM IDENTIFICATION

REMOVAL OR INSTALLATION OF DRAWERS

For Models With Drawers

- 1) Press lock-in tabs inward towards drawer side.
- 2) Lift front of drawer up and pull clear of slides.

Installation:

- 1) Place drawer on top of slides and push into rear stops.
- 2) Align slot in drawer slide with lock-in tabs and press in place. Lock-in tabs must be fully engaged in slots, otherwise damage may result to door pan.

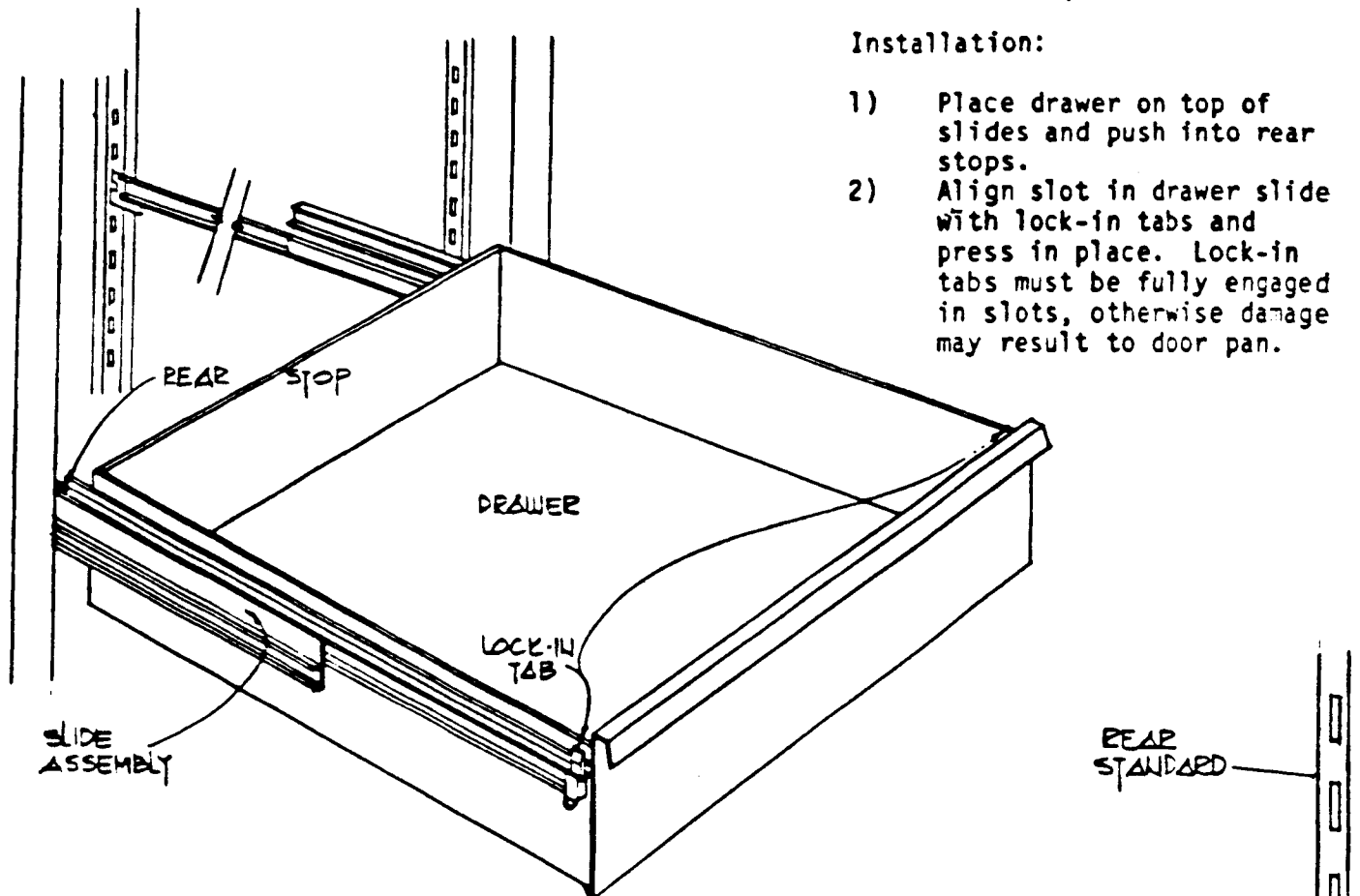

DRAWER SLIDE MOUNTING INSTRUCTIONS

Step #1: Push into slots in rear standard. Make certain that opposite drawer slides are in the same slots in the opposite standards.

Step #2: Push into slots in front standard and press down. If necessary, tap into place.

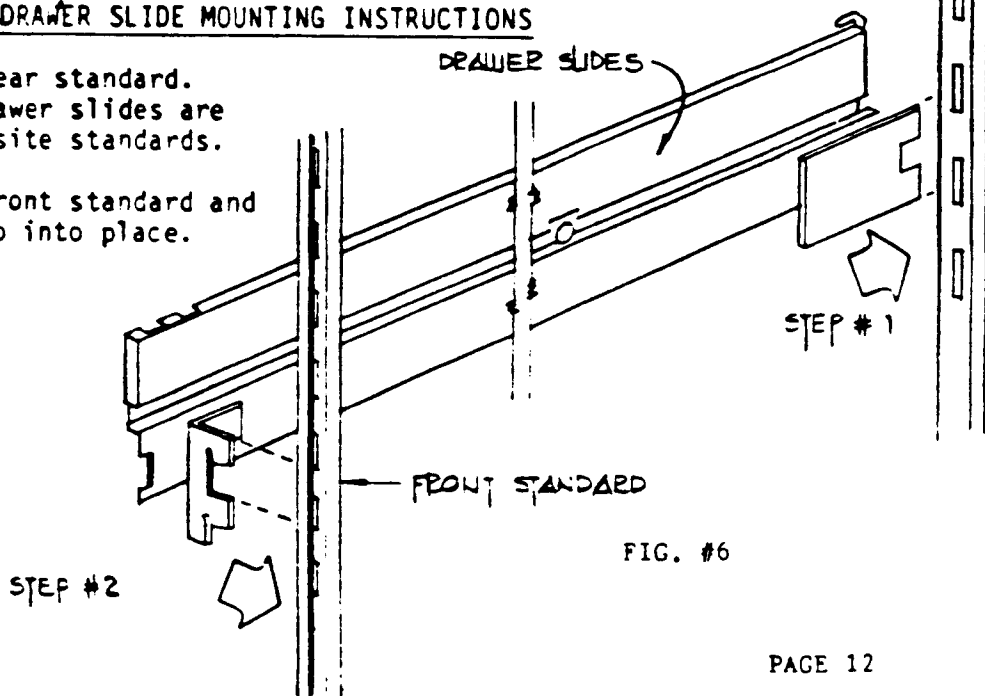

FIG. #6



TECUMSEH HERMETIC CONDENSING UNITS

MODEL AE4440AA

R 12

1/3 HP

AIR COOLED

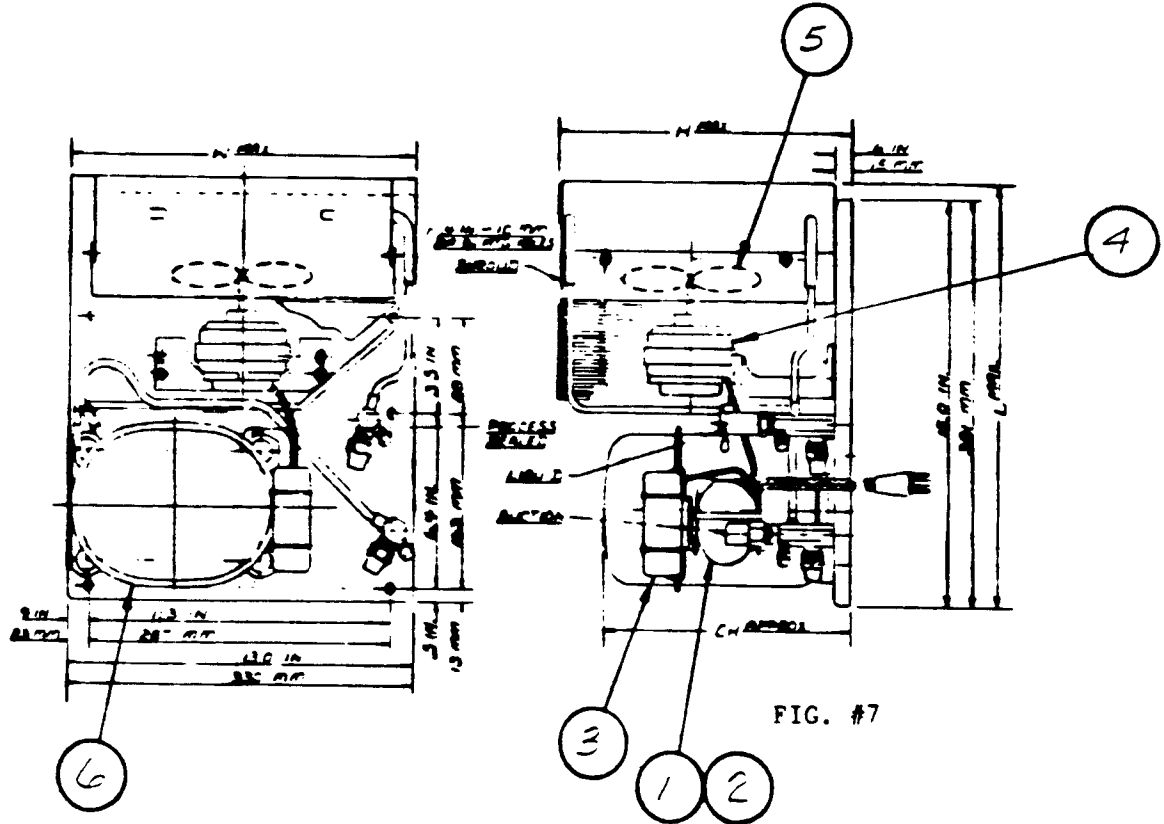

FIG. #7

Model	Dimensions				*Line Connections		Pumpdown 80°F 80% Full	Air CFM	Oil Chg Oz.	Gross Wt. Lbs.
	L	W	H	CH	Section	Liquid				
AE4440AA	15.6	13.2	11.1	9.4	3/8 F	3/8 F	---	--	10	48

*F = Flare, S = Solder, RF or RS = Rotolock Valve with Flare or Solder Connections

Factory Charge 20 psig Nitrogen - MUST BE EVACUATED

60 HZ. PERFORMANCE

Evaporator Approved		Ambient								
Range		80°F			100°F			110°F		
°F	PSIG	BTU / HR	Watts	Head	BTU / HR	Watts	Head	BTU / HR	Watts	Head
+20	21.0	2540	530	148	2330	535	170	2120	542	195
+30	28.4	3020	560	158	2800	565	181	2570	570	208
+35	32.6	3270	594	162	3030	600	189	2800	605	214
+40	37.0	3530	640	170	3280	645	196	3050	652	221
+45	41.7	3790	690	178	3540	700	204	3290	708	230
+50	46.7	4050	800	185	3800	810	212	3540	820	240

SPECIFICATIONS

Nominal Voltage	-----	115-60-1, 100-50-1
Unit B/M	-----	2B302-1
Voltage Range	-----	126.5 to 103.5
Min. Circuit Ampacity	--	9.0
Max. Fuse Size (Amps)	--	15
Compressor Model	-----	AE4440A
Bill of Material	-----	AE234AL-610-P1
RLA/LRA	-----	6.8/32.7
Cap. Cab. Assy.	-----	NR
Overload	-----	8300MRAC19
Relay	-----	82632
Relay Alternate	-----	82470
Cap. Start	-----	855S110C14
Rating	-----	145-175/110
Cap. Run	-----	NR
Rating	-----	---
Fan Motor	-----	810G006A13
Alternate	-----	810M006A17
Alternate	-----	810E006A65
Pressure Controls	-----	NR
Contactors	-----	NR
Crankcase Heater	-----	NR
Fan Controls	-----	NR
Control Panel Assy.	-----	NR
Fan Blade	-----	51510
Fan Guard	-----	NR
Condenser	-----	50792-1
Condenser Shroud	-----	70701
Receiver Tank	-----	NR
Unit Drawing	-----	DGU-1896-19
Schematic or Elect. Dwg.	-----	DEAE-2

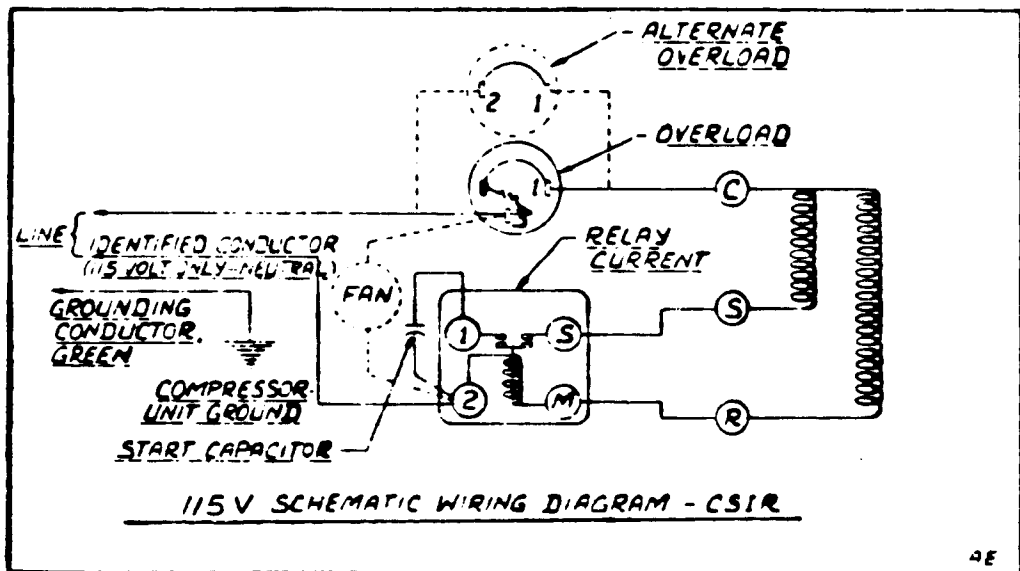

FIG. #8

U.L. Recognized (60 Hz. only) - File #SA2372 ---- Card Guide #SGYU
 CSA Certified ----- Canadian File #12964C ---- USA File #8873C

MODEL VA VEE-AIRE UNIT COOLER

BULLETIN 101.4
(Replaces Bulletin 101.3)



Recognized Component
Underwriter's Lab., Inc.



APPLICATION

The Vee-Aire is a deluxe unit designed for use in small reach-ins, back bar and under counter refrigerators, and many other applications where a small, compact unit is required. The thermal expansion valve mounts inside of the unit. The unit can be mounted from the ceiling or off the back wall or end walls; can be used in mullion applications.

THE COMPACT UNIT

FEATURES

- Attractive grained aluminum cabinet—lightweight, looks better, lasts longer, no paint to scratch!
- Captive fasteners provide easy, access to fan/drain panel for routine cleaning. Eliminates fastener loss.
- Molded Lexan® fan guard and fan — safety approved.
- Improved drain pan overlaps coil surface to catch all condensate.
- Stainless steel screws — prevent rust streaks.
- Plate-type aluminum fins with full collars on expanded copper tubes.
- Expansion valve mounts inside cabinet.
- Convenient, moisture-proof motor plug makes field connection easy. For plug-in simplicity, use the VA with optional plug wire harness or Lyall Electric plug F-3-5.
- Generous coil surface to provide proper compressor balance.
- Motors life lubricated and impedance protected.
- Top quality throughout in a compact size.
- All Models UL component recognized.
- NSF Approved.
- BohnKote® optional.

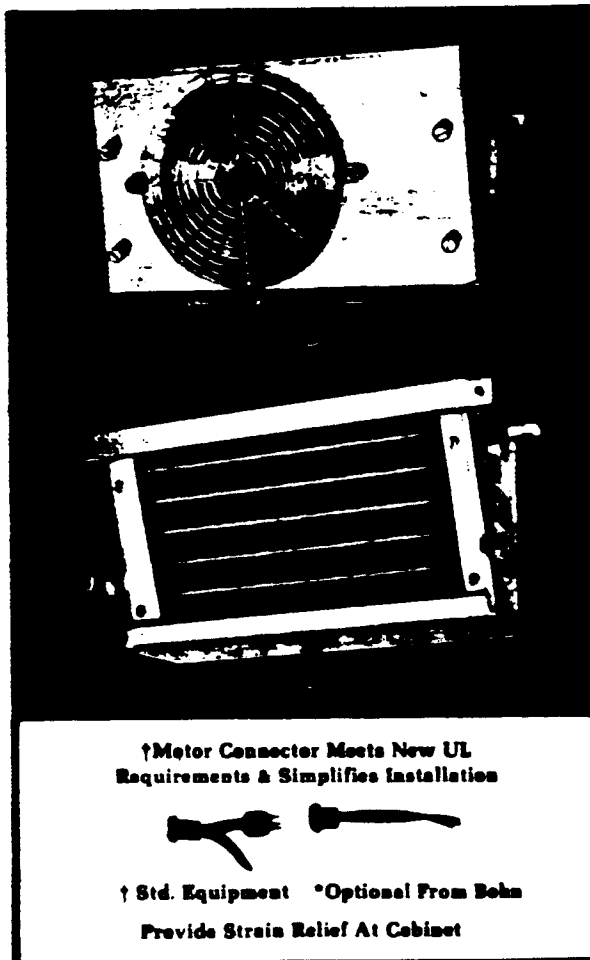

† Motor Connector Meets New UL
Requirements & Simplifies Installation



† Std. Equipment *Optional From Bohn
Provide Strain Relief At Cabinet

*MOLDED RECEPTACLES FOR
3-PRONG CONNECTORS (OPTIONAL)

Part Number	Lead Length
4318K001	30"
4318K002	48"

FIG. #9



Bohn Heat Transfer Division

Gulf - Western Manufacturing Company
Denville, Illinois 61832 • (217) 446-3710

Canadian Headquarters:
Bohn Heat Transfer Division
Gulf - Western (Canada) Ltd.
Mississauga, Ontario L4W 1E3
Telephone: (416) 624-1717

PRF116-15

PAGE 15

MODEL VA

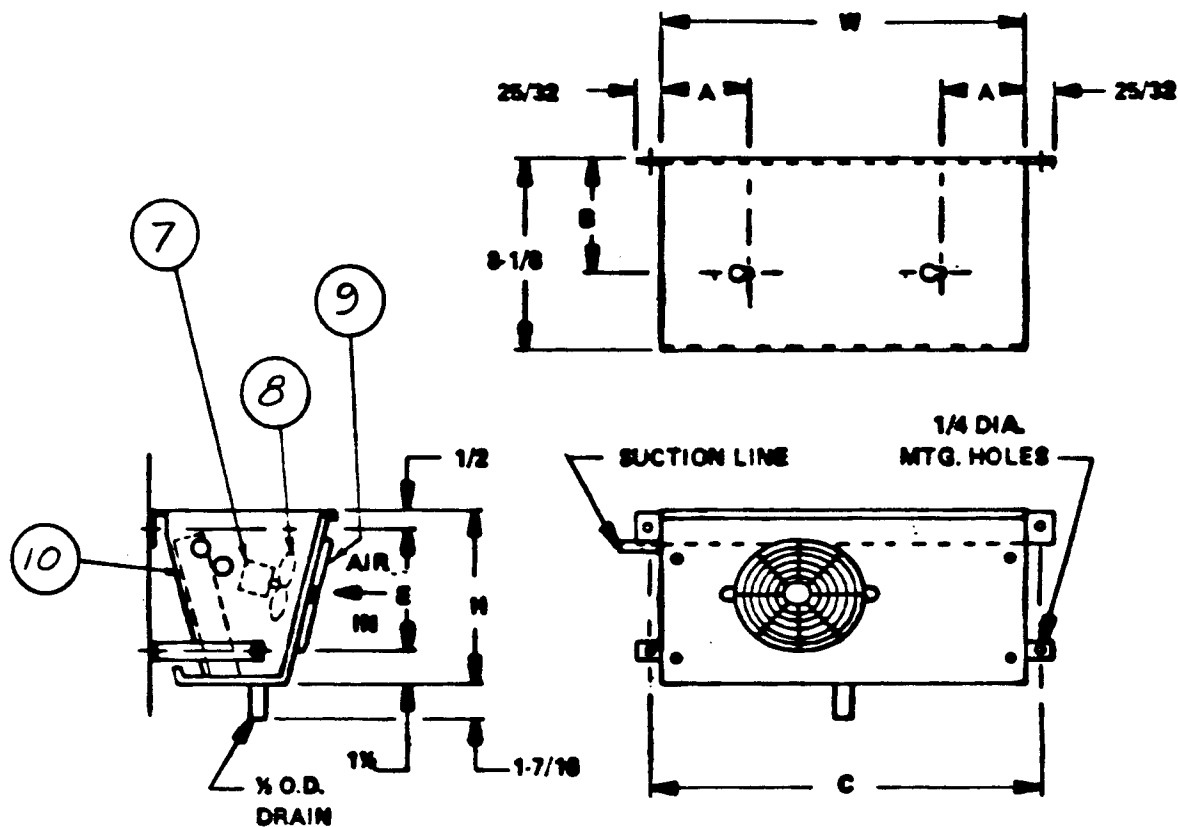

PHYSICAL DATA

SIZE	DIMENSIONS (In.)						CONNECTIONS (In.)			Approx. Ship Wt. (Lbs.)
	A	B	C	H	W	E	Coil Inlet	Section	Drain	
VA-012	2 $\frac{1}{2}$	4 $\frac{1}{2}$	18 $\frac{1}{2}$	8	18	6	$\frac{1}{2}$ FN	$\frac{1}{2}$ OD	$\frac{1}{2}$ OD	14

PERFORMANCE & ELECTRICAL DATA

SIZE	BTU PER HOUR (60 Hz)				CFM	MOTORS (60 Hz)		
	(TD In °F.)			115 Volts				
	1° TD	16° TD	18° TD	Qty.		Watts	Amps	
VA-012	120	1200	1800	200	2	70	1.28	

FIG. #10

SEE PARTS LIST FOR ITEM IDENTIFICATION

BOHN reserves the right to make changes in specifications or design at any time without notice and without obligation to purchasers or owners of previously sold equipment.

MOTORS

The motors are lifetime lubricated for trouble-free operation. The fan panel is readily removed for servicing the motor. 115/1/60 models are suitable for 110/1/50 operation.

MAINTENANCE

It is recommended that the unit be inspected occasionally for dirt accumulation. Grease and deposits should be removed from the fan, fan guard and drain pan. Entrance for interior cleaning is at captive fasteners (4) on panel.

REPLACEMENT PARTS

Table No. 3 gives the part numbers of the common replacement parts. When ordering parts, always give the complete model number and serial number of the unit.

	<u>TABLE NO. 3</u>	<u>ITEM</u>
Motor (115V)	5021-S	7
Fan Blade	5101-B	8
Fan Guard	5054-D	9

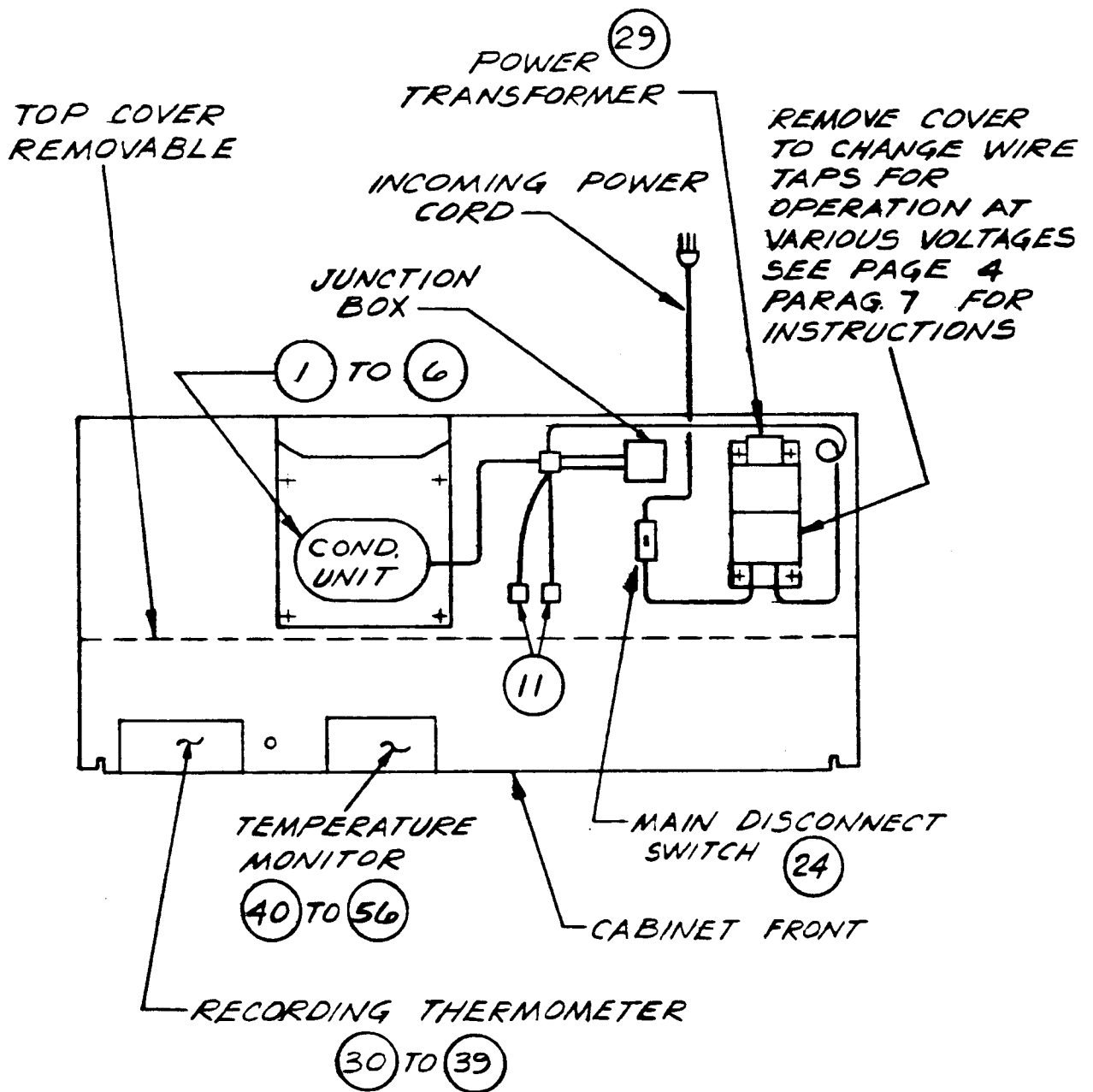

MECHANICAL COMPONENT PARTS LOCATIONS

FIG. #11

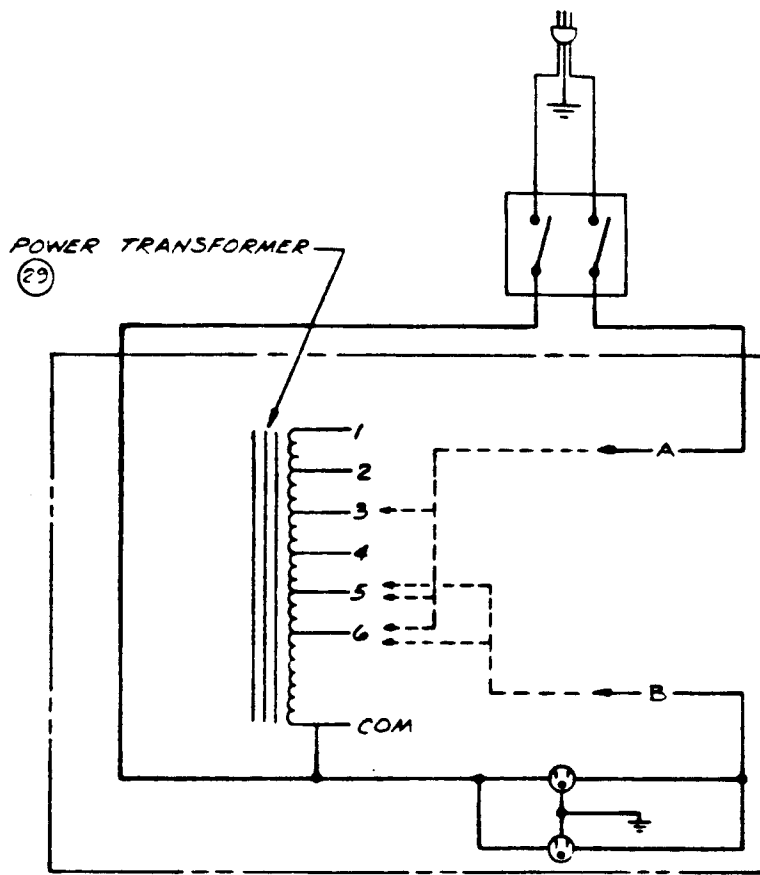

110 VOLT 50/60 CYCLE A C
OR
220 VOLT 50/60 CYCLE A C
PRIMARY POWER

110 VOLT SECONDARY POWER
@ 60 CYCLE OPERATION

105 VOLT SECONDARY POWER
@ 50 CYCLE OPERATION

SEE PAGE FOR
SETTING PROCEDURES

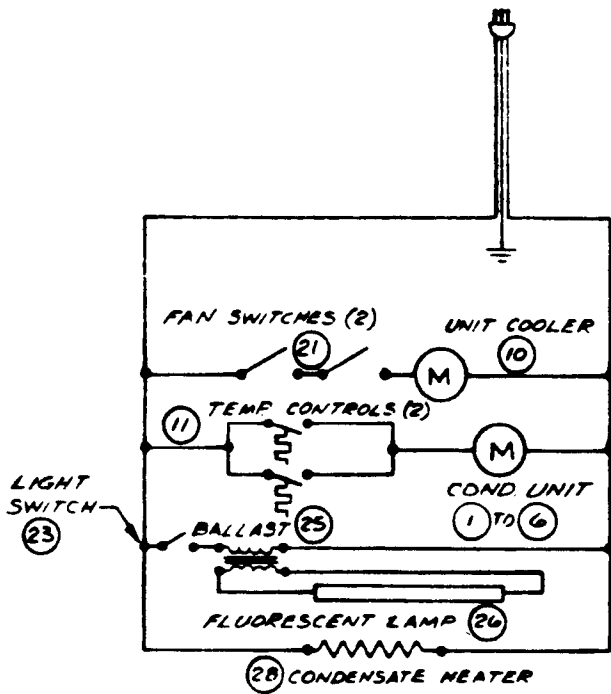
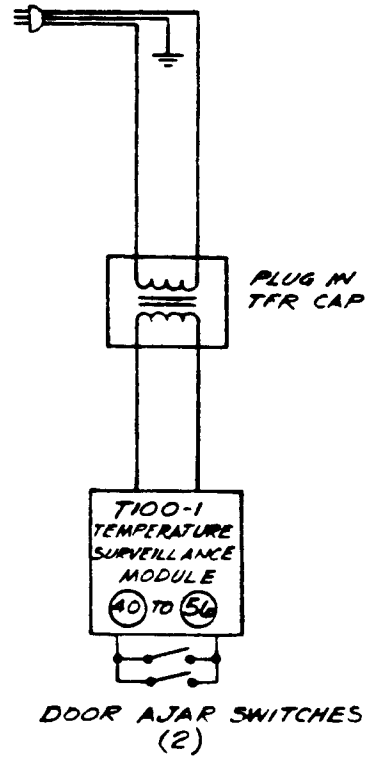

FIG. #12

STORAGE INSTRUCTIONS

If these refrigerators are to be stored, they must be kept in a controlled environment. Indoor storage is required with the temperature kept within a range of -20°F. to +120°F. (-29°C. to +49°C.).

Extended storage time may have an affect on the batteries located in the temperature module, as batteries have a limited shelf life. These batteries are of the rechargeable type and are automatically charged when the temperature module is on. If after 45 to 50 hours of use the batteries fail to hold a charge, they must be replaced with fresh batteries.

The only other component that may be affected by extended storage would be the pen arm located in the recording thermometer. After prolonged storage the pen arm may dry out and require replacement.

REPLACEMENT PART LIST

MODEL BBR37 BLOOD BANK REFRIGERATOR

<u>PER</u> <u>ITEM NO.</u>	<u>PART NO</u>	<u>FSCM</u>	<u>ITEM NAME</u>	<u>QUANTITY</u> <u>END ITEM</u>
1	8300MRAC19	594311	Overload, Condensing Unit	1
2	82632	59431	Start Relay, Condensing Unit	1
3	85PS110A75	59431	Start Capacitor, Condensing Unit	1
4	810E006A65	59431	Mtr, Condnsing Unit Fan 115-60-1	1
5	51510	59431	Blade, Condensing Unit Fan	1
6	AE4440A	59431	Motor Compressor 115-60-1	1
7	5021-S	14852	Motor, Unit Cooler Fan 115-60-1	1
8	5101-B	14852	Blade, Unit Cooler	1
9	5054-D	14852	Fan Guard	1
10	71906003	14852	Finned Coil, Unit Cooler	1
11	CTL001	32011	Control, Temperature	2
12	CPY001	32011	Capillary Drier Assemby	1
13	2830-2110	87518	Fastener & Strike Assembly, Door, "Klein"	2
14	2842-1009- 1110	87518	Hinge,Door,"Klein" 1- 1/8" Offset	4
15	SR1905-1	32011	Shim, Hinge	4
16	GKT014	32011	Gasket, Door	2
17	AR714-02A	32011	Drawer Slide Assembly	10
18	22-51-SSA	87518	Legs Stnls Stl Adjust, "Klein"	4
19	CHR002	32011	Card Holder, Plastic	5

REPLACEMENT PARTS LIST (Continued)

MODEL BBR37 BLOOD BANK REFRIGERATOR

<u>ITEM NO.</u>	<u>PART NO</u>	<u>FSCM</u>	<u>ITEM NAME</u>	<u>QUANTITY PER END ITEM</u>
20	BTL001	32011	Bottle, Plastic with Cap, 8oz	2
21	780-021	Littelfuse	Switch, N.O. for Unit Cooler	2
22	780-022	Littelfuse	Switch, N.C. for Door Ajar	2
23	SWT003	32011	Switch, Rotary for Interior Light	1
24	1102	Hubbell	Switch, Power S.T.D.P.	1
25	8G1063W	G.E.	Ballast, Fluorescent	1
26	F40C	G.E.	Lamp, Fluorescent	1
27	2776-1048- 3000	87518	Lamp Guard, Clear	1
28	HTR001	32011	Heater Element, Condensate	1
29	TFR023	32011	Transformer, 110/220/50/60,1000VA	1

Lamp Socket

(GENERAL TROUBLE SHOOTING)
SERVICE CHART

	SYMPTOM	POSSIBLE CAUSE	REPAIR
A	Compressor will not start--no hum	<ol style="list-style-type: none"> 1. Line disconnect switch open. 2. Fuse removed or blown. 3. Overload protector tripped. 4. Control stuck in open position. 5. Control off due to cold location. 6. Wiring improper or loose. 	<ol style="list-style-type: none"> 1. Close start or disconnect switch. 2. Replace fuse. 3. Refer to electrical section. 4. Repair or replace control. 5. Relocate control. 6. Check wiring against diagram.
B	Compressor will not start--hums but trips on overload protector	<ol style="list-style-type: none"> 1. Low voltage to unit. 2. Starting capacitor defective. 3. Relay failing to close. 4. Compressor motor has a winding open or shorted. 5. Internal mechanical trouble in compressor. 6. Improperly wired. 	<ol style="list-style-type: none"> 1. Determine reason and correct. 2. Determine reason and replace. 3. Determine reason and correct, replace if necessary. 4. Replace compressor. 5. Replace compressor. 6. Check wiring against diagram.
C	Compressor starts, but does not switch off of start winding	<ol style="list-style-type: none"> 1. Low voltage to unit. 2. Relay failing to open. 3. Run Capacitor defective. 4. Excessively high discharge pressure. 5. Compressor motor has a winding open or shorted. 6. Internal mechanical trouble in compressor (tight). 7. Improperly wired. 	<ol style="list-style-type: none"> 1. Determine reason and correct. 2. Determine reason and correct, replace if necessary. 3. Determine reason and replace. 4. Check discharge shut-off valve, possible overcharge, or insufficient cooling on condenser. 5. Replace compressor. 6. Replace compressor. 7. Check wiring against diagram.
D	Compressor starts and runs, but short cycles on overload protector	<ol style="list-style-type: none"> 1. Excessive discharge pressure. 2. Low voltage to unit (or unbalanced if three phase). 3. Overload protector defective. 4. Run capacitor defective. 5. Compressor too hot--return gas hot. 6. Suction pressure too high. 7. Compressor motor has a winding shorted. 8. Additional current passing through overload protector. 	<ol style="list-style-type: none"> 1. Check ventilation, restrictions in cooling medium, restrictions in refrigeration system. 2. Determine reason and correct. 3. Check current, replace protector. 4. Determine reason and replace. 5. Check refrigerant charge (fix leak) add if necessary. 6. Check for possibility of misapplication. Use stronger unit. 7. Replace compressor. 8. Check wiring diagram. Check for added fan motors, pumps, etc., connected to wrong side of protector.

(GENERAL TROUBLE SHOOTING)
SERVICE CHART

	SYMPTOM	POSSIBLE CAUSE	REPAIR
E	Unit runs OK, but short cycles on	<ol style="list-style-type: none"> 1. Overload protector. 2. Thermostat. 3. High pressure cut-out due to: <ol style="list-style-type: none"> a. insufficient air or water supply. b. overcharge. c. air in system. 4. Low pressure cut-out due to: <ol style="list-style-type: none"> a. liquid line solenoid leaking. b. compressor valve leak. c. undercharge. d. restriction in expansion device. 	<ol style="list-style-type: none"> 1. Replace device. 2. Differential set too close--widen. 3. <ol style="list-style-type: none"> a. Check air or water supply to condenser--correct. b. Reduce refrigerant charge. c. Purge. 4. <ol style="list-style-type: none"> a. Replace. b. Replace. c. Fix leak, add refrigerant. d. Replace device.
F	Unit operates long or continuously	<ol style="list-style-type: none"> 1. Shortage of refrigerant. 2. Control contacts stuck or frozen 3. Refrigerated or air conditioned space has excessive load or poor insulation. 4. Dirty Condenser. 5. Evaporator coil iced. 6. Restriction in refrigeration system. 7. System inadequate to handle load. 8. Filter dirty. 	<ol style="list-style-type: none"> 1. Fix leak, add charge. 2. Clean contacts or replace control. 3. Determine fault and correct. 4. Clean condenser. 5. Defrost. Check defrost circuit. 6. Determine location and remove. 7. Replace with larger system. 8. Clean or replace.
G	Start capacitor open, shorted or blown	<ol style="list-style-type: none"> 1. Relay contacts not opening properly. 2. Prolonged operation on start cycle due to: <ol style="list-style-type: none"> a. low voltage to unit. b. improper relay. c. starting load too high. 3. Excessive short cycling. 4. Improper capacitor. 	<ol style="list-style-type: none"> 1. Clean contacts or replace relay if necessary. 2. <ol style="list-style-type: none"> a. Determine reason and correct. b. Replace. c. Correct by using pump down arrangement if necessary. 3. Determine reason for short cycling and correct. 4. Determine correct size & replace.
H	Run capacitor open, shorted or blown	<ol style="list-style-type: none"> 1. Improper capacitor. 2. Excessively high line voltage (110% of rated max.). 	<ol style="list-style-type: none"> 1. Determine correct size and replace. 2. Determine reason and correct.
I	Relay defective or burned out	<ol style="list-style-type: none"> 1. Line voltage too high or too low 2. Excessive short cycling. 3. Incorrect relay. 4. Incorrect mounting angle. 5. Relay being influenced by loose vibrating mounting. 6. Incorrect run capacitor. 	<ol style="list-style-type: none"> 1. Determine reason and correct. 2. Determine reason for short cycling and correct. 3. Check and replace. 4. Remount relay in correct position. 5. Remount rigidly. 6. Replace with proper capacitor.

(GENERAL TROUBLE SHOOTING)
SERVICE CHART

	SYMPTOM	POSSIBLE CAUSE	REPAIR
J	Space temperature too high	<ol style="list-style-type: none"> 1. Control setting too high. 2. Expansion valve too small. 3. Cooling coils too small 4. Inadequate air circulation. 	<ol style="list-style-type: none"> 1. Reset control. 2. Use larger valve. 3. Add surface or replace. 4. Improve air movement.
K	Suction line frosted or sweating	<ol style="list-style-type: none"> 1. Expansion valve passing excess refrigerant or is oversized. 2. Expansion valve stuck open. 3. Evaporator fan not running. 4. Overcharge of refrigerant. 	<ol style="list-style-type: none"> 1. Readjust valve or replace with smaller valve. 2. Clean valve of foreign particles, replace if necessary. 3. Determine reason & correct. 4. Correct charge.
L	Liquid line frosted or sweating	<ol style="list-style-type: none"> 1. Restriction in filter drier. 2. Liquid shut-off (king valve) partially closed. 	<ol style="list-style-type: none"> 1. Replace part. 2. Open valve fully.
M	Unit noisy	<ol style="list-style-type: none"> 1. Loose parts or mountings. 2. Tubing rattle. 3. Bent fan blade causing vibration. 4. Fan motor bearing worn. 	<ol style="list-style-type: none"> 1. Find and tighten. 2. Reform to be free of contact. 3. Replace blade. 4. Replace motor.
N	Unit cools but does not get to set point	<ol style="list-style-type: none"> 1. Fan not operating. 	<ol style="list-style-type: none"> 1. Check door switch. a. Check to see if door switch actuator (angle) is depressing switch.

NOTE: Jewett Refrigerators and Freezers are designed to operate in areas that are heated to 60°F. Installation in unheated areas may require a low temperature compressor protection kit for satisfactory operation.



7-Day Recording Thermometer

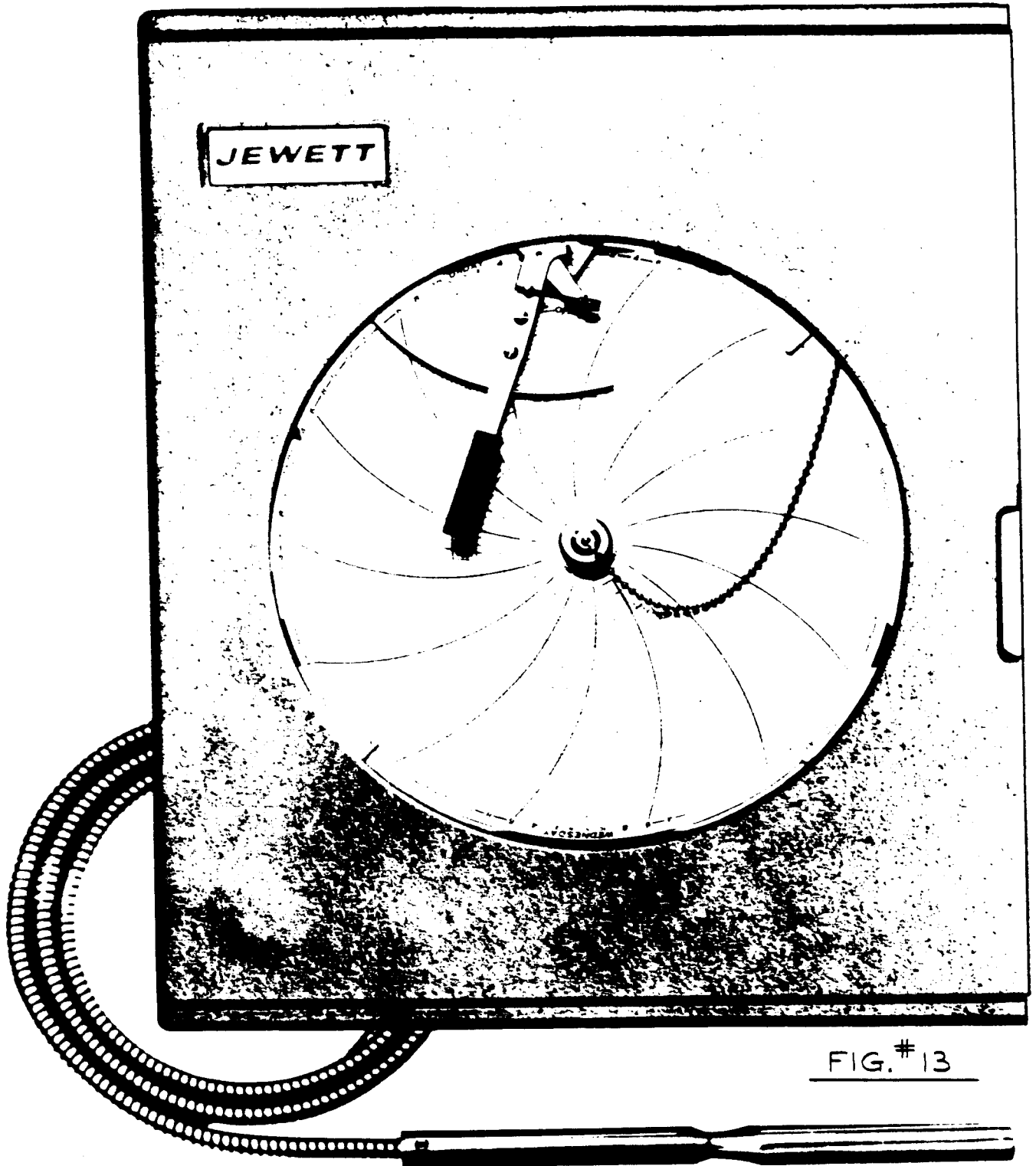

FIG. # 13

Model 8GR1WBR for Refrigerators

GENERAL INFORMATION

The Jewett 7-day Recording Thermometer is a sensitive and specially designed instrument for keeping permanent and accurate blood temperature records. It provides uninterrupted observation of stored blood temperatures pathologists require to determine the extent of damage that can be caused by temperature fluctuations. They can then decide whether the blood can still safely be used. This is a necessary feature for modern blood banks in answering any technical or legal questions that may arise.

The Jewett Recording Thermometer records in Celsius readings.

This 7-day spring-wound instrument features the Mark-a-Matic II continuous flow inking system. Each fiber-tipped pen has its own sealed, specially formulated ink supply and provides up to 8 months of fine line temperature recording. This pen has a sealed, self-contained ink supply that is specially formulated to insure continuous flow without skipping or blotting. The flexible stainless steel pen arm easily inserts into pen and is attached to the recording thermometer by two screws. A temperature sensitive stainless steel encapsulated sensor is immersed in liquid. In the event of a power failure, there is a complete record of the rise of temperature while the current is off, as well as its fall with the restoration of power. The unit is furnished with 100 8-inch centigrade charts.

STANDARD FEATURES

Jewett offers a recording device that features:

- . Mark-a-Matic inking system.
- . Stainless steel sensor.
- . Stainless steel armoured capillary cable.
- . 7-day spring-wound mechanism. Insures continuous record of temperature fluctuations in event of power failure.
- . Continuous accurate record-keeping on quick, easy-to-read charts.
- . 100 8" (203 mm) charts supplied with each recorder.
- . Chart number RDR019 charts (-12°C to +43°C).

GENERAL INFORMATION

- A. Read instructions carefully before using the instrument.
- B. The recorder is shipped with the following accessories.

One box of 100 charts
One chart drive winding key

- C. When ordering replacement parts, refer to the part name and number in the parts list. Always specify model and serial number when ordering.

This instrument is guaranteed to function under all normal conditions. With proper care it will render lasting accurate service.

CAPILLARY TUBING

Avoid bending the tubing sharply. All excess tubing is coiled and installed inside mechanical compartment.

CALIBRATION

This recorder has been accurately calibrated at the factory. Before making any adjustments, the instrument should be in operation for at least 48 hours. Thereafter, should any adjustment be necessary, check the recorder's temperature readings against an accurate test thermometer.

This is done by placing the bulb of the test thermometer alongside the bulb of the recorder, in a well agitated liquid bath. Then compare the readings after the bulbs have been held in the bath for five (5) minutes. If the recorder does not check with the test thermometer, correction can be made by means of the adjusting screw at the upper right of the pen arm. If sufficient correction cannot be obtained in this manner, it is recommended that the factory be notified, giving exact details including model and serial number. Do not ship the recorder back to the factory for readjustment or repair without written authorization from the factory.

CHART DRIVE (MECHANICAL)

Wind the chart drive each time when changing the chart. With the chart removed, insert the winding key through the hole in the chart plate and wind arbor in the direction indicated by the arrow on the plate. DO NOT OVERWIND. An observation cutout has been provided in the chart plate to observe the balance wheel to ascertain whether the chart drive is operating. Be sure on/off switch located under chart plate is in the "on" position.

If the chart does not start after winding, reinsert the key and release suddenly after winding the chart drive fully. Repeat if necessary.

PEN LIFTER

A pen lifter has been provided to raise the pen off the chart whenever required. The pen is raised by pulling on the metal tab located at the upper left-hand corner of the chart plate. The pen is lowered by depressing the tab.

(continuation)

REPLACEMENT OF CHARTS

Raise the pen lifter as far as it will go. This will provide approximately 1/2" (13 mm) of clearance for the removal of the chart. To remove the chart, unscrew the knob at the center of chart. Position the new chart so that the correct time line coincides exactly with the red pointer on the chart plate. Then replace center chart knob and screw tightly against chart. Lower pen gently onto chart by depressing pen lifter fully. A small dot of ink appearing where the pen point touches the chart will indicate that the pen will trace properly.

INKING PEN

The pen system consists of a self-contained ink reservoir with a porous plastic stylus which is slipped onto the outboard end of the pen arm, firmly. Two screws are provided at the upper end of the pen arm to provide adjustment of its length so that the pen tracks the time line on the chart. Check this after each replacement of the pen and adjust accordingly. Remove colored cap. If stylus does not quite touch the chart, adjustment can be made by slightly bending the pen arm in the center. Do not have more pressure than necessary to make a fine line.

NOTE: AS THE INK SUPPLY NEARS EXHAUSTION, THE INK COLOR BECOMES LIGHTER. THIS INDICATES THAT THE PEN SHOULD BE REPLACED.

REMOVAL OF CHART PLATE

To remove the chart plate, insert index fingers into the openings at the lower left and right hand corners of the chart plate. Press upward against the top of the spring loaded chart plate posts with thumbs and lift the chart plate off the posts. Push the chart plate towards the top of the recorder and remove.

To replace chart plate, position the openings at the upper edge of the chart plate on the upper chart plate posts. This will locate the chart plate correctly over the lower plate posts. Then snap it into position by depressing lower edge.

7-DAY RECORDING THERMOMETER MODEL: 8GRIWBR

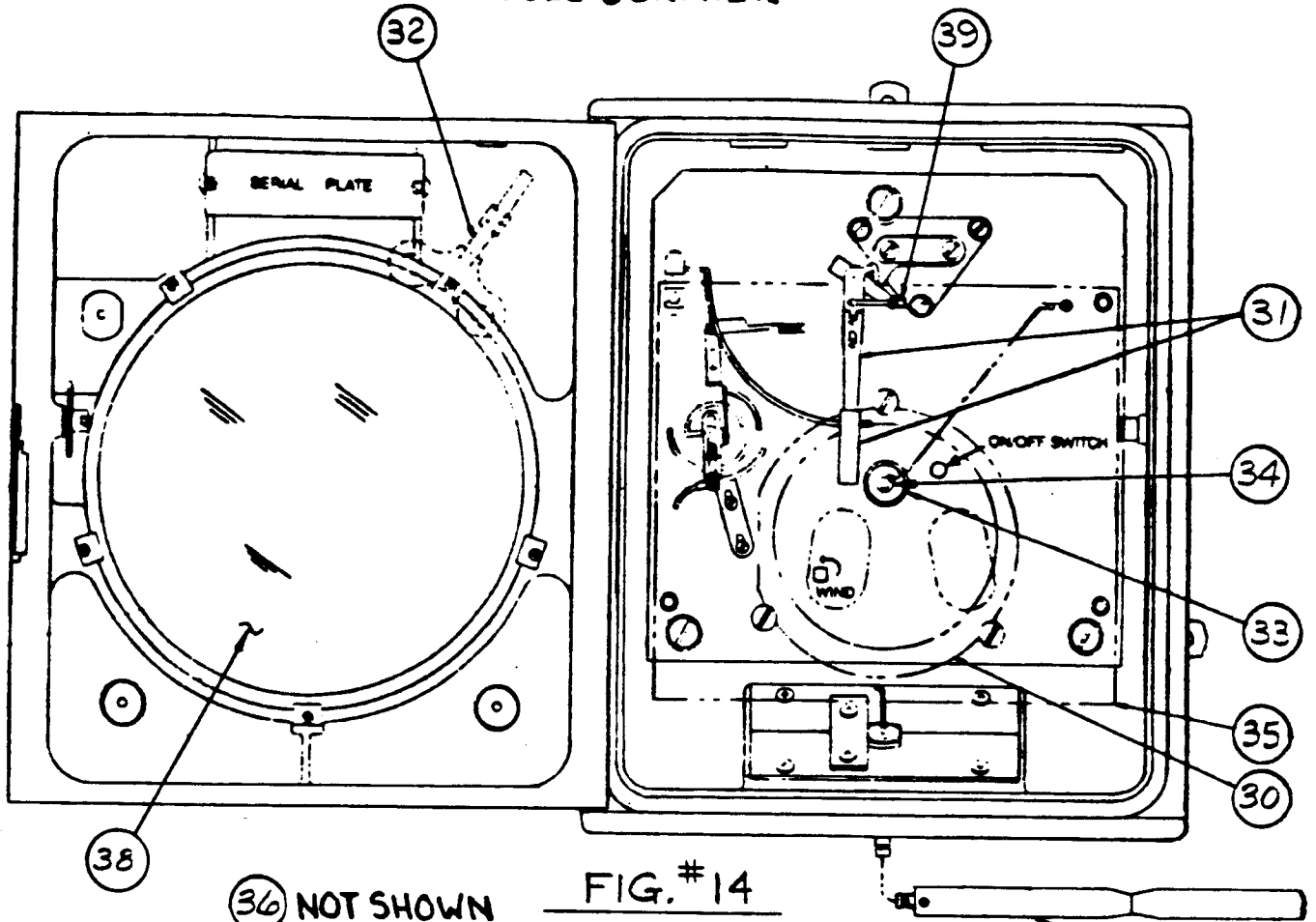

RECORDER CASE DIMENSIONS (Inches shown, mm in parentheses)

Overall case size is 10-1/8 (257) wide x 12-3/8 (314) high x 4-15/16 (125) deep.

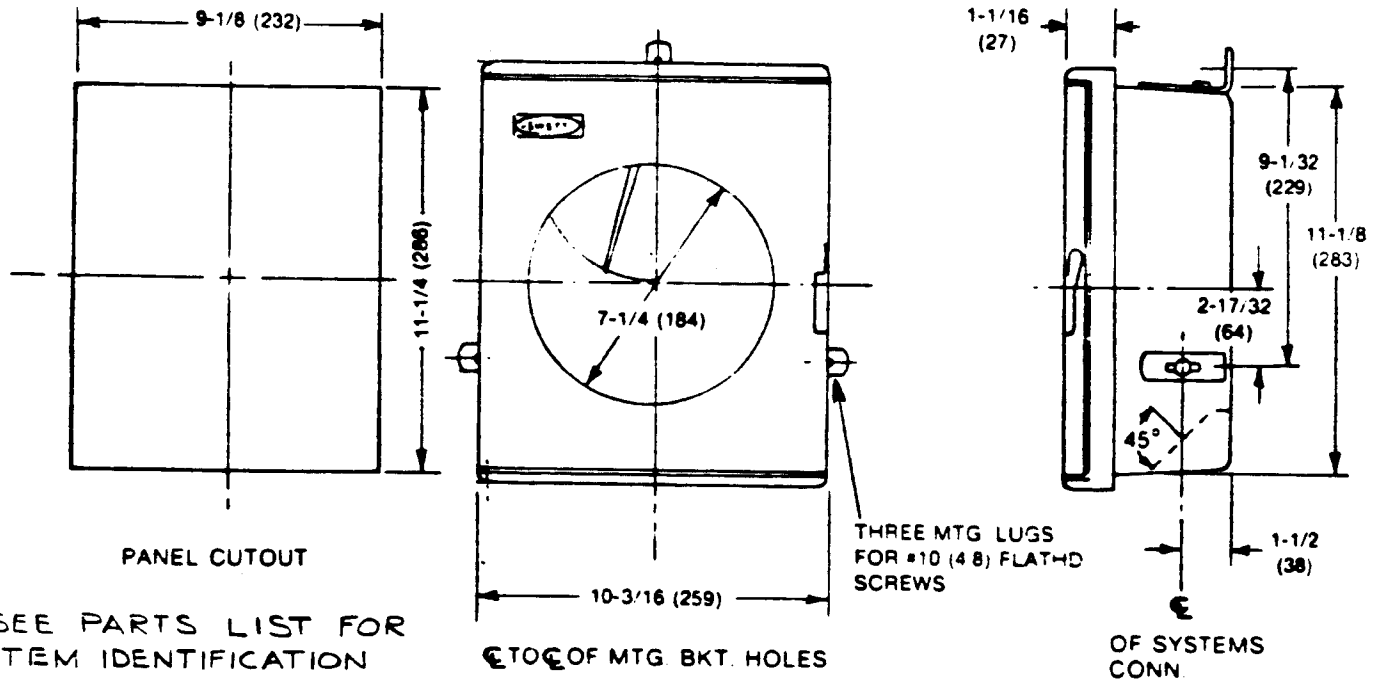

SEE PARTS LIST FOR
ITEM IDENTIFICATION

TO OF MTG BKT. HOLES

FIG. #15

REPLACEMENT PART LIST

MODEL 8GR1WBR FOR RECORDING THERMOMETER

<u>ITEM NO.</u>	<u>PART NO</u>	<u>FSCM</u>	<u>ITEM NAME</u>	<u>QUANTITY PER END ITEM</u>
30	RDR010	32011	CHART DRIVE - 7 DAY SPRING WOUND	1
31	RDR024	32011	MARK-A-MATIC II KIT CONSISTING OF: (6) DISPOSABLE PENS (1) PEN ARM	1
32	RDR027	32011	KEY, WINDING, CHART DRIVE	1
33	RDR013	32011	KNOB, CHART WITH BEADED CHAIN	1
34	RDR006	32011	HUB, CHART	1
35	RDR044	32011	PLATE, CHART	1
36	RDR019	32011	CHART (J7-12+43-8) 100	
37	RDR005	32011	THERMAL SYSTEM (-12 to +43°C)	1
38	RDR003	32011	GLASS, DOOR	1
39	RDR007	32011	SCREW, MICROMETER ADJUSTMENT (PEN ARM)	1

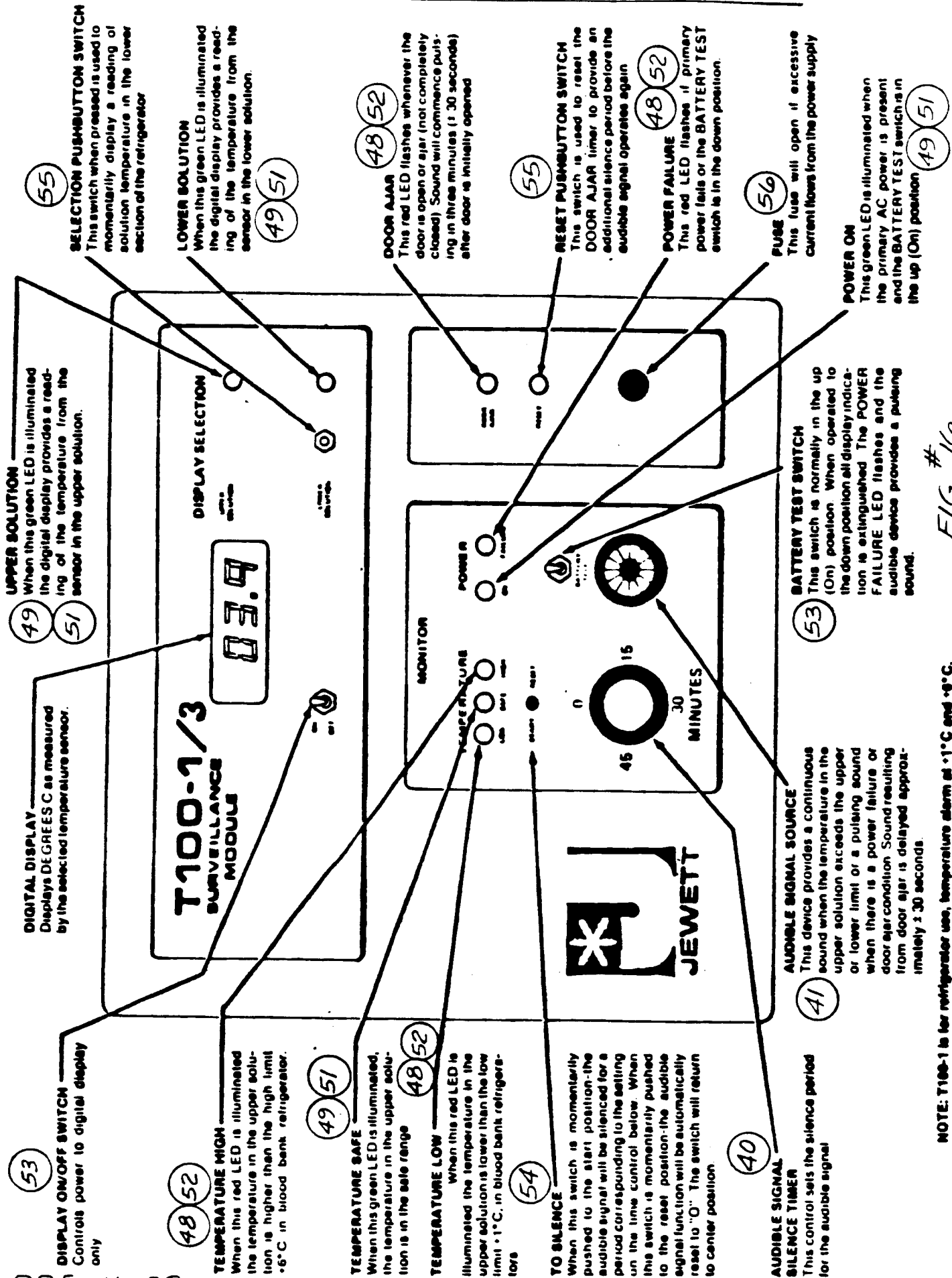

PRF 116-112

FIG. #16

NOTE: T100-1 is for refrigerator use, temperature alarm at +1°C and +9°C.

**GENERAL INFORMATION:
JEWETT TEMPERATURE SURVEILLANCE MODULE**

The Jewett Temperature Surveillance Module is a sophisticated precision electronic instrument. Its primary purpose is to assure the user of stored product safety. The module is designed to be a separate and distinct system which operates and functions independently from the refrigeration control system.

Five (5) basic functions are performed by the module:

1. Constant, 24 hour, surveillance of temperature within the refrigerator cabinet.
2. Constant display of solution (or product) temperature with provision for user to select and momentarily display temperature in another location within the refrigerator cabinet.
3. Constant monitoring of the presence of primary power to the refrigerator.
4. A DOOR AJAR status indicator.
5. Low battery indication.

The monitoring of these five key areas and the automatic warning and specific identification of a malfunction permits immediate corrective action to be taken by responsible persons to eliminate dangerous and costly stored product spoilage.

Installation or removal can be accomplished by referring to Page 36, Fig. 17 and proceeding as follows.

A. To REMOVE module:

1. Unplug low voltage power supply from convenience outlet located in the mechanical compartment on top of the blood bank refrigerator.
2. Unplug two (2) quick disconnects identified as (A), (B).
3. Remove connections from terminal strip located on top of Logic Control Board. Unplug door ajar plug and power cord.
4. Unfasten six (6) retaining nuts from the rear of the module face panel.
5. The module is now electrically and mechanically disconnected and can be removed.

B. To INSTALL module:

1. Place module in position and securely fasten six (6) retaining nuts.
2. Make electrical connections to terminal strip on top of Logic Control Board.

General Information (Jewett Temp. Surveillance Module) (cont'd.)

3. Plug together the two (2) quick disconnects identified as (A), (B), (sensors A and B are interchangeable) by carefully mating the pins and keyway.
4. Plug the low voltage power supply into the convenience outlet located in the mechanical compartment on top of the blood bank.
5. Remove sensor (A) from the 8 oz. plastic bottle in the upper refrigerator cabinet interior. Fill the bottle with 10% glycerine in water solution. Insert sensor (A) into bottle, making certain that the sensor is immersed into the liquid until the solution is within 1/2" of the top of the bottle.

Note: To reduce evaporation of liquid, seal the top of the bottle opening with plastic cover provided.

6. Remove sensor (B) from the plastic bottle in the lower refrigerator cabinet interior and proceed as in step 5 above.
7. Connect stand-by battery (9VDC alkaline) located on top of the module rear protective/dust cover by clipping the polarized wiring adaptor to the battery terminals.
8. Module is now electrically and mechanically installed.

OPERATION OF THE MODULE

Page 32 Fig 16 of this manual illustrates and identifies the location of various operational functions. The module face panel has three sections: 1-Display, 2-Monitor, 3-Door Ajar. When all monitored functions are in the safe condition, the following indications are identified by the module:

MONITOR SECTION

This section (which is the heart of the module) monitors the temperature of the upper solution within the refrigerator cabinet and presence or absence of primary power. The temperature monitoring is performed by a thermistor sensor. This section also includes the audible signal device, a battery test switch and a timed audible silencing switch. With all conditions safe, the green LED safe temperature lamp is illuminated and the green LED power ON lamp is illuminated. To perform a battery test, actuate the BATTERY TEST SWITCH. This will cause the extinguishing of all display indication and the flashing of the red power failure lamp, the audible signal will emit a pulsing sound.

DIGITAL DISPLAY SECTION

With the ON/OFF switch in the normal ON position, the digital display indicates the temperature of the upper solution within the refrigerated cabinet and the green LED upper solution lamp is illuminated. To display the lower solution temperature, depress the lower solution push button switch. The instrument now senses and momentarily displays lower solution temperature within the lower section of the cabinet. This mode of operation is indicated by the extinguishing of the green LED upper solution lamp and the illumination of the green LED lower solution lamp. After momentary display, the unit automatically returns to displaying the upper solution temperature. In this mode, the green LED lower solution lamp is extinguished and the green LED upper solution lamp is illuminated.

DOOR AJAR SECTION

This section consists of a red LED Door Ajar lamp, a reset pushbutton switch and a fuse. When the refrigerator door is properly closed, no indication is present. Whenever the door is intentionally or unintentionally open (ajar) the red LED Door Ajar lamp will flash. If the door remains open for approximately three (3) minutes (+ 30 seconds), a pulsing audible signal will be heard. If it is necessary for the door to remain open after the audible signal sounds, depress the door alarm reset push-button and the audible signal will be silenced for an additional three minutes.

LOW BATTERY CONDITION

When the stand-by battery requires replacement, a pulsating audible signal will sound and the Power Failure LED will be illuminated (Power ON LED will also be on).

ALARM CONDITIONS

When an unsafe condition occurs, the monitor section warns of unsafe conditions and identifies the type of failure. The following will cause an alarm condition:

The upper solution temperature becomes unsafe, (either too high or low). When an unsafe temperature occurs, the green LED safe temperature lamp is extinguished and the appropriate red LED lamp, high or low, is illuminated indicating the nature of the temperature alarm. The audible device emits a continuous sound. The audible output may be silenced for a period of 0 to 45 minutes by setting the silence timer and then moving the start switch to "Start". When the temperature returns to a safe condition, the module automatically indicates a safe condition.

If the primary power source to the refrigerator fails, the green LED power ON lamp is extinguished, the red LED power failure lamp flashes and the audible signal emits a pulsing sound. The audible can be silenced by the timed audible silencing switch. When power is restored, the module automatically indicates safe condition.

T100 CONNECTION DIAGRAM

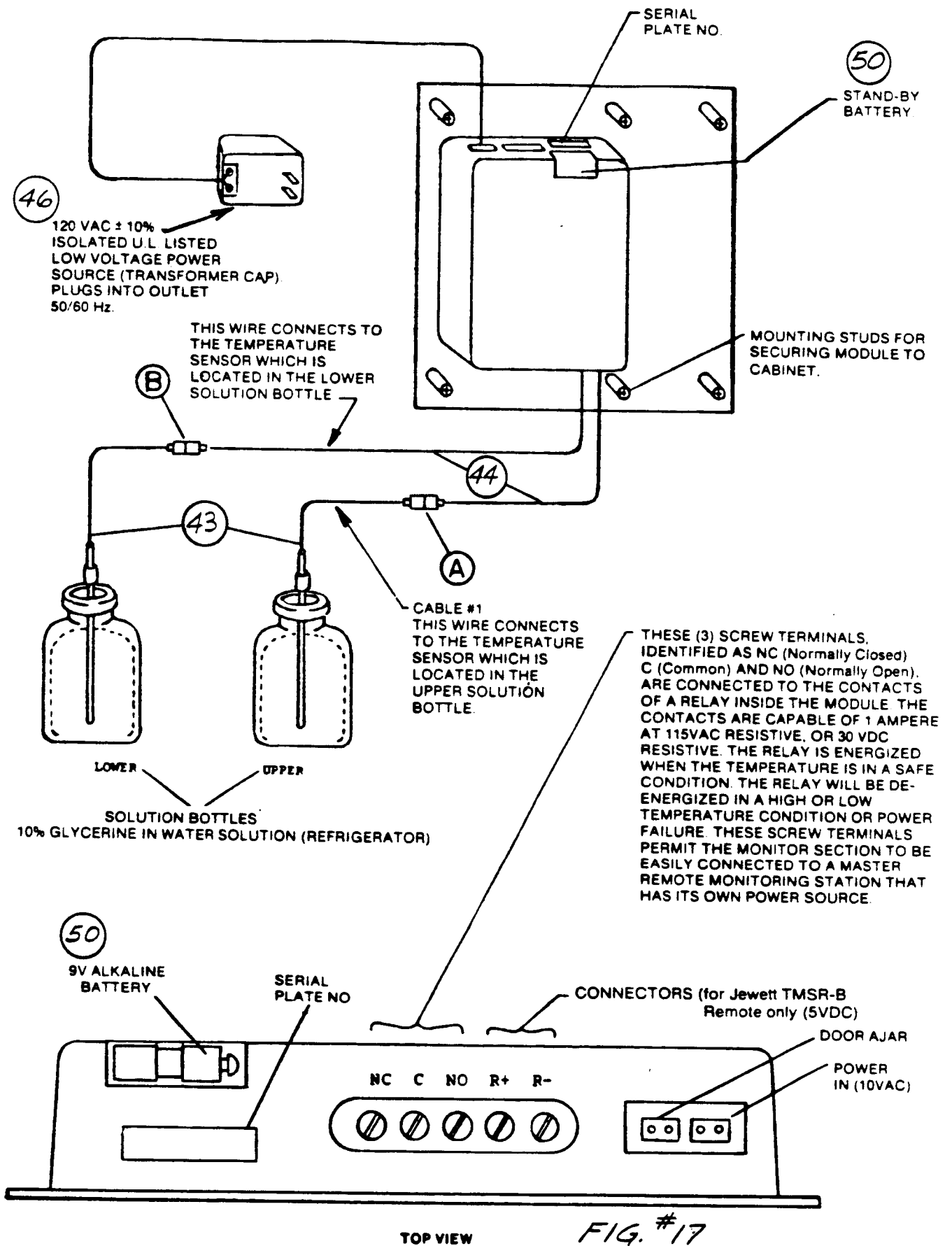

TROUBLE-SHOOTING CHART Model Series T100-1

	CONDITION INDICATED ON INSTRUMENT DIGITAL TEMPERATURE DISPLAY SECTION				POSSIBLE CAUSE	SUGGESTED REPAIR
	DIGITAL DISPLAY LAMP	UPPER SOLUTION LAMP	LOWER SOLUTION SWITCH	LOWER SOLUTION PUSH BUTTON		
1	On-Reading Correct	On	Off	Pressed Momentarily	Push Button Switch or Circuit Malfunction.	Replace Switch or Contact Jewett Service
2	On-Reading Correct	Off	Off	Not Pressed Momentarily	Upper Lamp or Circuit Malfunction.	Replace Lamp or Contact Jewett Service
3	On-Reading Correct	Off	Off	Pressed Momentarily	Lower Lamp or Circuit Malfunction	Replace Lamp or Contact Jewett Service
4	On-Reading Correct	On	On	Pressed or Not Pressed	Circuit Malfunction	Contact Jewett Service
5	On-Reading Correct	Off	On-But Recycles to Upper Lamp Immediately	Pressed Momentarily	Circuit Malfunction.	Contact Jewett Service
6	On-Reading Incorrect	On	Off	Not Pressed	Upper Solution Thermistor Sensor or Circuit Malfunction.	Check Calibration Replace Sensor or Contact Jewett Service
7	On-Reading Incorrect	Off	On	Pressed Momentarily	Lower Solution Thermistor Sensor or Circuit Malfunction	Check Calibration Replace Sensor or Contact Jewett Service

	CONDITION INDICATED ON INSTRUMENT DIGITAL TEMPERATURE DISPLAY SECTION				POSSIBLE CAUSE	SUGGESTED REPAIR
	DIGITAL DISPLAY LAMP	UPPER SOLUTION LAMP	LOWER SOLUTION SWITCH	LOWER SOLUTION PUSH BUTTON		
8	On-Reading -12.6	On	Off	Not Pressed	Upper Solution Sensor Disconnected or Open Circuit	Connect Sensor or Contact Jewett Service
9	On-Reading -12.6	Off	On	Pressed Momentarily	Lower Solution Sensor Disconnected or Circuit Malfunction	Connect Sensor or Contact Jewett Service
10	Off	On	Off	Not Pressed	Digital Meter Switch Off or Meter Malfunction	Turn Switch On or Contact Jewett Service
11	Off	On	Off	Pressed Momentarily.	Digital Meter Switch Off or Meter Malfunction	Turn Switch On or Contact Jewett Service
12	Reading Minus Rather Than Plus Temperature	On	Off	Not Pressed	Meter Malfunction (Ascertain that Actual Temperature is Plus)	Contact Jewett Service
13	As Above	Off	On	Pressed Momentarily	As Above	Contact Jewett Service
14	Segment of Any	Either Condition	Either Condition	Either Condition	Meter Malfunction	Contact Jewett Service
15	Decimal Point Out	Either Condition	Either Condition	Either Condition	Meter Malfunction	Contact Jewett Service

TROUBLE-SHOOTING CHART Model Series T100-1

CONDITION INDICATED ON MONITOR SECTION										POSSIBLE CAUSE	SUGGESTED REPAIR
TEMPERATURE			POWER		AUDIBLE	TIMER	BATTERY				
Cabinet	LIGHTS		LIGHTS	On	Failure	Sound	Silence	Test Switch			
	Low	Safe							High		
Safe	Off	On	Off	On	Off	Off	Zero Time	Up	None	Normal Operation	
Safe	Off	On	Off	On	Flashing Light	Pulsing Sound	Zero Time	Up	Replace Battery	Battery Weak	
Safe	Off	Off	Off	Off	Flashing Light	Pulsing Sound	Zero Time	Up	Plug in Trans-former Cap Replace Fuse	Transformer Cap Unplugged Fuse Open	
Safe	Off	On	Off	Off	Off	Off	Zero Time	Up	Replace LED on Circuit board Contact Jewell Service	Power on LED not lighting. Circuit Malfunction	
Safe	Off	Off	Off	On	Off	Off	Zero Time	Up	Replace LED on Circuit board Contact Jewell Service	Safe LED not lighting. Circuit Malfunction	
Too Cold 15° C	Off	Off	Off	On	Off	Off	Zero Time	Up	Replace LED on Circuit board Contact Jewell Service	Low LED not lighting. Circuit Malfunction	
Too Warm 55° C	Off	Off	Off	On	Off	Off	Zero Time	Up	Replace LED on Circuit Board Contact Jewell Service	High LED not lighting. Circuit Malfunction	
Safe	Off	Off	Off	Off	On	Off	Zero Time	Up	Replace Audible Device Contact Jewell Service	Audible device Malfunction. Circuit Malfunction	

DOOR AJAR SECTION				POSSIBLE CAUSE	SUGGESTED REPAIR
DOOR AJAR LED	RESET	AUDIBLE	DOOR STATUS		
On Pulsing	Not Pressed In	Pulses at Proper Time	Closed	Reset switch Malfunction. Door Switch Malfunction. Circuit Malfunction	Replace Reset Switch. Replace Door switch. Contact Jewell Service
On Constant	Not Pressed In	Off	Open	Circuit Malfunction	Contact Jewell Service
On Constant	Not Pressed In	On Constant	Open	Circuit Malfunction	Contact Jewell Service
On Pulsing	Not Pressed In	Off (Never Pulses)	Open	Circuit Malfunction	Contact Jewell Service
On Pulsing	Not Pressed In	On (No Delay)	Open	Circuit Malfunction	Contact Jewell Service
Off	Not Pressed In	Off (Never Pulses)	Open	Reset Switch Malfunction. Door Switch Circuit Malfunction	Replace Switch or Contact Jewell Service
Off	Not Pressed In	Pulses at Proper Time	Open	Lamp Defective or Circuit Malfunction	Replace Lamp or Contact Jewell Service
Off	Not Pressed In	Off (Never Pulses)	Open	Door Switch Malfunction or Wire Open to Unit	Replace Switch Correct Open Circuit

TROUBLE-SHOOTING CHART

Model Series T100-1

CONDITION INDICATED ON MONITOR SECTION							POSSIBLE CAUSE	SUGGESTED REPAIR
TEMPERATURE		POWER		AUDIBLE	TIMER	BATTERY		
Cabinet	LIGHTS		LIGHTS	Sound	Silence	Test Switch		
	Low	Safe	High	On	Off	On	Failure	
High or Low	On	Off	On	On	45 Min	Up	Replace Timer, Replace Start / Reset Switch, Contact Jewett Service	
Safe	On	On	On	On	Zero Time	Up	Contact Jewett Service	
Safe	On	On	Off	On	Zero Time	Up	Contact Jewett Service	
Safe	Off	On	On	On	Zero Time	Up	Contact Jewett Service	
Safe	On	On	Off	On	Zero Time	Up	Contact Jewett Service	
Safe	On	Off	On	On	Zero Time	Up	Contact Jewett Service	
Safe	Off	Off	Off	Constant On	Zero Time	Down	Contact Jewett Service	

CONDITION INDICATED ON VOLTMETER OR OHMMETER MEASUREMENT REMOTE OUTPUT CIRCUIT				POSSIBLE CAUSE	SUGGESTED REPAIR
TERMINALS	READING	TEMPERATURE STATUS	POWER		
• and -	+5 VDC	Safe	On	Normal	Remove Short Contact Jewett Service
• and -	0 VDC	Safe	Off		
• and -	+5 VDC	High or Low	On		
JG CIRCUIT					
TERMINALS	READING	TEMPERATURE STATUS	POWER		
1 CMN and NO	0 OHMS	SAFE	On	Normal	
2 CMN and NO	Infinite OHMS	Not Applicable	Off	Normal	
3 CMN and NO	Infinite OHMS	Safe	On	Relay or Circuit Malfunction	Replace Relay Contact Jewett Service
4 CMN and NO	0 OHMS	Not Applicable	Off	Relay or Circuit Malfunction	Replace Relay Contact Jewett Service
5 CMN and NC	Infinite OHMS	Safe	On	Normal	
6 CMN and NC	0 OHMS	Not Applicable	Off	Normal	
7 CMN and NC	0 OHMS	Safe	On	Relay or Circuit Malfunction	Replace Relay Contact Jewett Service
8 CMN and NC	Infinite OHMS	Not Applicable	Off	Relay or Circuit Malfunction	Replace Relay Contact Jewett Service
9 CMN and NO	Infinite OHMS	High or Low	On	Normal	
10 CMN and NO	0 OHMS	High or Low	On	Relay or Circuit Malfunction	Replace Relay Contact Jewett Service
11 CMN and NC	0 OHMS	High or Low	On	Normal	
12 CMN and NC	Infinite OHMS	High or Low	On	Relay or Circuit Malfunction	Replace Relay Contact Jewett Service

REPLACEMENT PART LIST

MODEL #T100 TEMPERATURE SURVEILLANCE MODULE

<u>ITEM NO.</u>	<u>PART NO</u>	<u>FSCM</u>	<u>ITEM NAME</u>	<u>QUANTITY PER END ITEM</u>
40	MOD-D0005	32011	TIMER ASSEMBLY	1
41	MOD-D0006	32011	AUDIBLE ASSEMBLY	1
42	MOD-D0003	32011	MAIN BOARD ASSEMBLY	1
43	MOD-D0008	32011	THERMISTOR SENSOR ASSY	2
44	MOD-D0009	32011	THERMISTOR CABLE ASSY	2
45	MOD-D0010	32011	DOOR AJAR PLUG ASSEMBLY	1
46	MOD-D0011	32011	POWER SUPPLY ASSEMBLY	1
47	MOD-D0001	32011	CALIBRATION PLUG	1
48	MOD-D0012	32011	LENS, RED	4
49	MOD-D0013	32011	LENS, GREEN	4
50	522	EVER- READY	BATTERY, ALKALINE 9VDC	1
51	HLMP-3502	HEWLETT- PACKARD	LED, GREEN	4
52	HLMO-3300	HEWLETT- PACKARD	LED, RED	4
53	7101SYCBE	C & K	SWITCH, ON/OFF - BATT. TEST	2
54	7105SYCQE	C & K	SWITCH, START/RESET	1
55	MSPS-103C-2	ALCO- SWITCH	SWITCH, DOOR AJAR - LOWER SOLUTION	2
56	AGC1, 250V	BUSS	FUSE	1

T100-1

CALIBRATION PROCEDURE

- 1) ALLOW T100 TO OPERATE FOR A MINIMUM OF 30 MINUTES.
- 2) T100-1 INSERT 10° C. CALIBRATION PLUG ONTO END OF UPPER SOLUTION THERMISTOR CABLE.
- 3) DISCONNECT DOOR AJAR, 10VAC, REMOTE CONNECTIONS AND BATTERY. REMOVE FOUR SCREWS ON BACK OF COVER AND REMOVE COVER. RECONNECT DOOR AJAR, 10VAC, REMOTE CONNECTIONS AND BATTERY.
- 4) ADJUST R6 IF CALIBRATION IS REQUIRED (LOCATED IN THE LOWER LEFT HAND CORNER OF THE MAIN CONTROL BOARD AS SEEN LOOKING DOWN FROM THE TOP) FOR A READING OF 10.0° C. FOR T100-1
- 5) REMOVE CALIBRATION PLUG FROM UPPER SOLUTION THERMISTOR CABLE, AND RECONNECT THE UPPER THERMISTOR.
- 6) DISCONNECT DOOR AJAR, 10VAC, REMOTE CONNECTIONS AND BATTERY. REPLACE REAR COVER. CALIBRATION IS NOW COMPLETE. RECONNECT DOOR AJAR, 10VAC, REMOTE CONNECTIONS AND BATTERY.

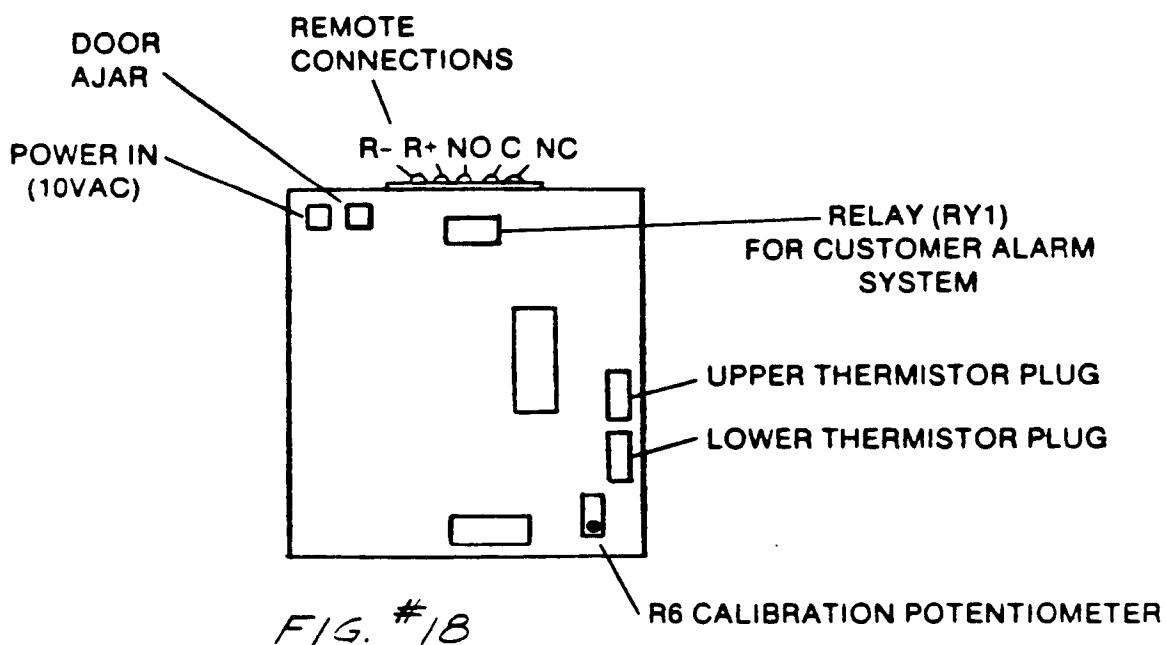

REAR VIEW (COVER REMOVED)

* - SEE CLAMPT BELLOW

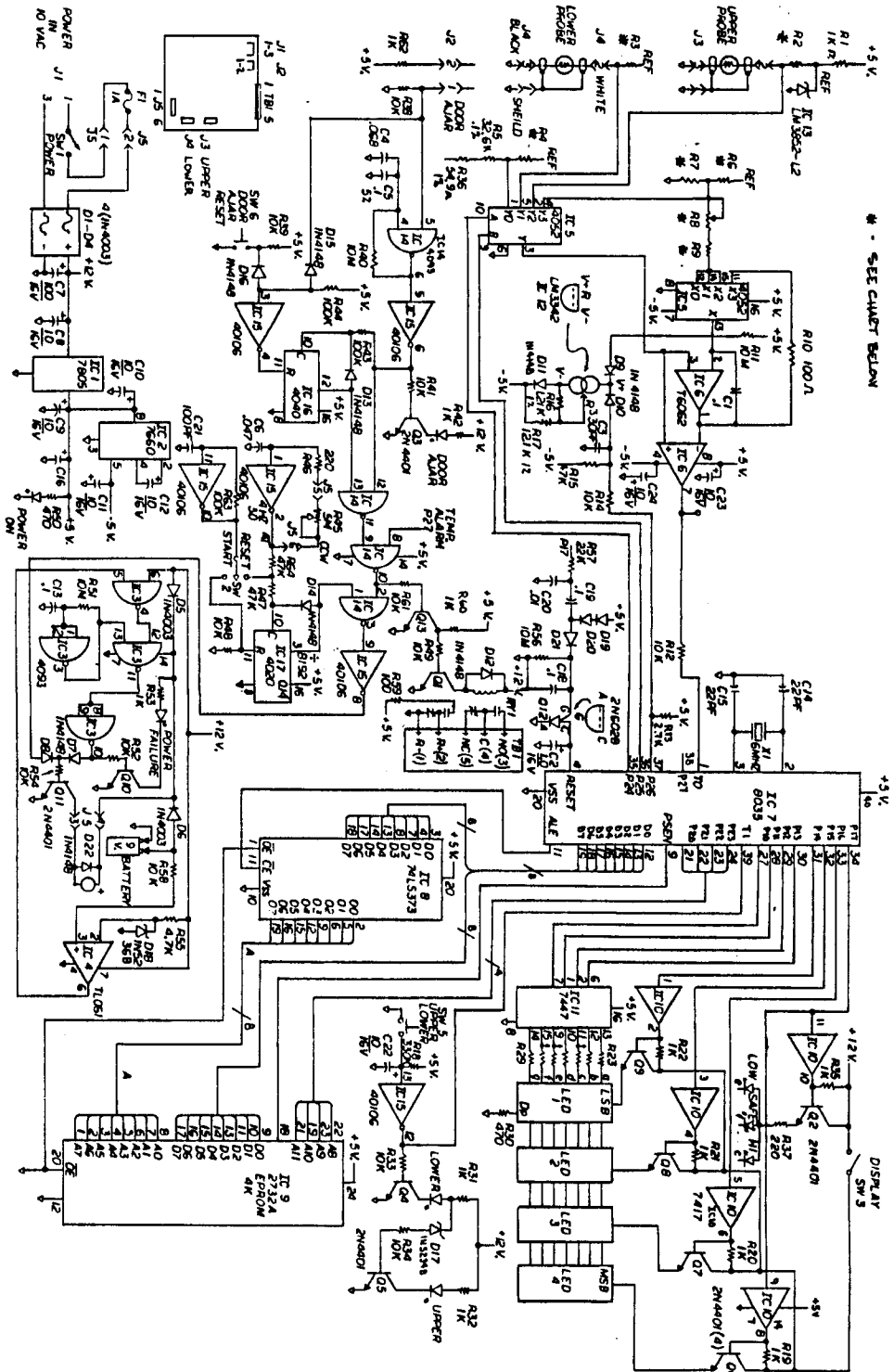

ITEM	T100-1	T100-3
R1	1K	1K
R2	1K	1K
R3	1K	1K
R4	1K	1K
R5	1K	1K
R6	1K	1K
R7	1K	1K
R8	1K	1K
R9	1K	1K

TEMP	LED'S
T100-1	T100-3
LOW	SAFE
SAFE	F
HIGH	C

PDF 116-42

JEWETT

REFRIGERATION COMPANY, INC.

REPAIRS AND SERVICE

1000 100th St. N.E. Minneapolis, MN 55431

WIRING SCHEMATIC

MODEL 4 T100D T100-1B
 4 T100D 5000-1B
 4 T100D 5000-1B
 4 T100D 5000-1B

DR-487 1

PAGE 4 OF 19
 FIGURE NO 19

REPLACEMENT PART LIST
MODEL #T100 TEMPERATURE SURVEILLANCE MODULE

<u>ITEM NUMBER</u>	<u>ITEM NAME</u>	<u>DESCRIPTION</u>		<u>QTY. PER END ITEM</u>
R1	RESISTORS	1K	1%	1
R2, R3, R4		27.4K	.1%	3
R5		32.6K	.1%	1
R6		154	1%	1
R7		348	1%	1
R8		1K	POT	1
R9		6.81K	1%	1
R10		100		1
R11, R40, R51, R56		10M		4
R12, R14, R33, R34 R38, R39, R41, R48 R49, R52, R54, R58 R61		10K		13
R15, R47, R64	47K		3	
R13	2.7K		1	
R16	1.21K	1%	1	
R17	12.1K	1%	1	
R18	330K		1	
R19, R20, R21, R22 R31, R32, R35, R42 R53, R60, R62	1K		11	
R23, R24, R25 R26, R27, R28 R29	150		7	
R30, R50	470		2	
R36	54.9	1%	1	
R37, R46	220		2	
R43, R44, R63	100K		3	
R45* *(NOT ON MAIN BOARD)	5M	POT	1	
R55	4.7K		1	
R57	22K		1	
R59	100	1/2W	1	
C1, C5, C13, C18, C19	CAPACITORS	.1	MYLAR	5
C2		1.0	16V	1
C3		330pf	DISC	1
C4		.068	MYLAR	1
C6		.047		1
C7		1000	16V	1
C8, C9, C10 C11, C12, C16, C22, C23, C24		10	16V	9

REPLACEMENT PART LIST

MODEL #T100 TEMPERATURE SURVEILLANCE MODULE

<u>ITEM NUMBER</u>	<u>ITEM NAME</u>	<u>DESCRIPTION</u>	<u>QTY. PER END ITEM</u>
C14, C15	CAPACITORS [cont'd.]	22 pf DISC	2
C20		.01	1
C21		.001 DISC	1
D1, D2, D3 D4, D5, D6	DIODES	1N4003	6
D7, D8, D10, D11 D12, D13, D14, D15, D16, D19, D20, D21		1N4148	12
D9, D18		1N5236B	2
D17		1N5234B	1
Q1, Q2, Q3, Q4, Q5, Q6, Q7, Q8, Q9, Q10, Q11, Q13	TRANSISTORS	2N4401	12
Q12		2N6028	1
IC1	INTEGRATED CIRCUITS	7805	1
IC2		ICL7660	1
IC3, IC14		4093	2
IC4		TL061CP	1
IC5		4052	1
IC6		TL062CP	1
IC7		8035	1
IC8		74L5373	1
IC9* *(EPROM MUST BE PROGRAMMED)		2732A	1
IC10		7417	1
IC11		7447	1
IC12		LM334Z	1
IC13		LM385Z1.2	1
IC15		40106	1
IC16		4040	1
IC17		4020	1
RY1	MISCELLANEOUS	RELAY P/N 1495-2C-12D LED DISPLAY P/N 5082-7750	1 4

